

Honeywell

GSMVLP
GSM Module with 2-Way Voice
Installation and Programming Guide



**Requires
Compass Version
1.5.8.54A (or higher)
for GSM
Downloading**

Table of Contents

| | |
|--|-----------|
| GENERAL INFORMATION | 3 |
| System Features | 3 |
| Remote Services Features | 3 |
| GSMVLP Module Kit..... | 4 |
| Installing the GSMVLP Module | 4 |
| Opening the Lynx Plus or ReadyGuard Plus Series Control..... | 4 |
| Mounting the GSMVLP..... | 4 |
| Programming the GSMVLP Module | 5 |
| Using the AlarmNet Direct website | 5 |
| Using the 7720P Programming Tool | 6 |
| Programming Conventions..... | 7 |
| PROGRAMMING..... | 7 |
| ECP Mode Programming..... | 7 |
| Setting up the Multi-Mode Feature..... | 9 |
| Configuring Multi-Mode..... | 9 |
| Setting up the Remote Access Feature..... | 10 |
| Enabling Remote Access..... | 10 |
| Selecting the User Interface..... | 11 |
| ECP Status Codes | 12 |
| Exiting Programming Mode | 12 |
| Setting the Factory Defaults | 13 |
| REGISTRATION..... | 13 |
| Registering the GSMVLP..... | 13 |
| Registering through AlarmNet Direct Website | 14 |
| Using the Test Message/Registration Switch | 14 |
| Using the Programming Tool..... | 14 |
| Replacing an existing module using the programming tool..... | 15 |
| Register by Phone | 15 |
| PROGRAMMER KEYBOARD COMMANDS..... | 16 |
| Module Identification Displays..... | 16 |
| GSMVLP Status Displays..... | 17 |
| APPENDIX A..... | 19 |
| SUMMARY OF LED OPERATION..... | 19 |
| GSMVLP Status Display Operation..... | 19 |
| Minimum Signal Strength LED Operation..... | 19 |
| CENTRAL STATION MESSAGES | 20 |
| GSMVLP DOWNLOADING | 20 |
| GLOSSARY | 21 |
| SPECIFICATIONS | 22 |

GENERAL INFORMATION

The GSMVLP is an optional communication module intended for use with Lynx Plus Series/ReadyGuard Plus Series controls, and provides wireless communication with the AlarmNet network for **backup delivery** of alarm and other messages to the monitoring central station. It also supports voice communications between the control panel and the Central Station.

Honeywell's GSMVLP cellular communication module transmits signals via the AlarmNet-G network (GSM cellular network), using GPRS and forwards them to your Central Station. If the GPRS network is unavailable, the GSMVLP will attempt to send the transmission via SMS (Short Message Service).

System Features

- Quick connection to compatible Lynx Plus Series/ReadyGuard Plus Series control panels
- Simple programming using a 7720P programming tool or via the AlarmNet Website
- Reports fire, burglary, and status messages via GSM
- Allows uploading and downloading of control panel data via GSM
- Uses 2-way ECP communication with the control.
- Enables two-way voice (AAV) communication between the control and central station via GSM
- Sends reports in Contact ID format
- Supports remote control of alarm system via Remote Services Feature
- Fully powered (primary and backup battery) from the control

The GSMVLP provides the following types of supervision and module fault detection:

- **Network communication failure:** In the event the AlarmNet network does not hear a supervisory message from the module within a specified time ("Supervision" option, 24 hours, 30 days, or none), AlarmNet notifies the central station of a communication failure.
- **Communication path failure:** In the event the module detects a communication path failure, the control panel can be notified of a trouble condition with the module after a specified time has elapsed.

Remote Services Features



The Remote Services Features can only be used with Lynx Plus Series/ReadyGuard Plus Series controls Revision 16 or later. Multi Mode (E-mail notification) is intended as a convenience for the user, and does not replace Central Station reporting of critical events (alarms, troubles, etc.).

Remote Services allow the end user to communicate with their Security System remotely via several features. Availability of this service is controlled by the dealer via the web-based programming tool on the AlarmNet Direct website. Once enabled, the specific programming fields associated with these features can be programmed either remotely using the AlarmNet Direct website or locally using the 7720P Programming Tool. These new web services will allow users to:

- Receive e-mail and text message notification of system events (Multi-Mode feature)
- Access their security system from a computer via a website (Remote Access feature)
- Perform system functions and receive confirmations using text messages (SMS feature)



The GSMVLP module requires an AlarmNet account. For new installations, please obtain the account information from the central station prior to programming this module.

GSMVLP Module Kit

This kit contains the following components:

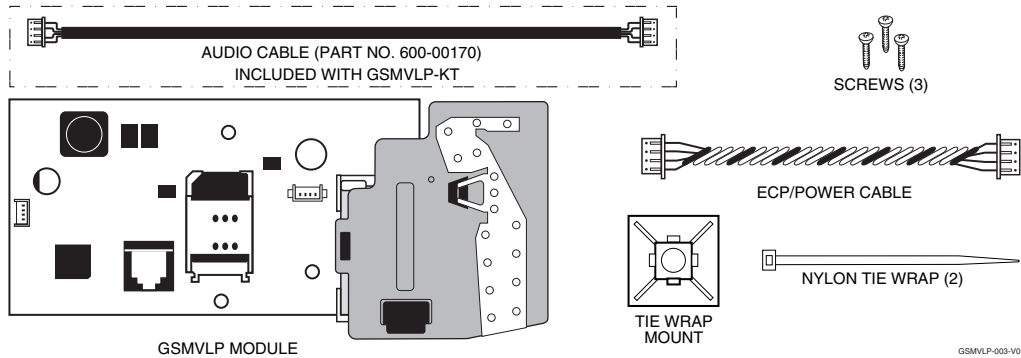

Figure 1 – GSMVLP Kit Components

Installing the GSMVLP module



1. Disconnect power from the control, including the battery, BEFORE installing the GSMVLP module.
2. **CAUTION: ESD SENSITIVE DEVICE.** To discharge any static buildup, briefly touch a chassis ground point before installing this module. Avoid performing this installation while standing on a carpeted floor.

Opening the Lynx Plus or ReadyGuard Plus Series Control and Installing GSMVLP

1. Install the provided FCC/IC label (P/N 800-05190) on the control's back case as shown on Figure 2.

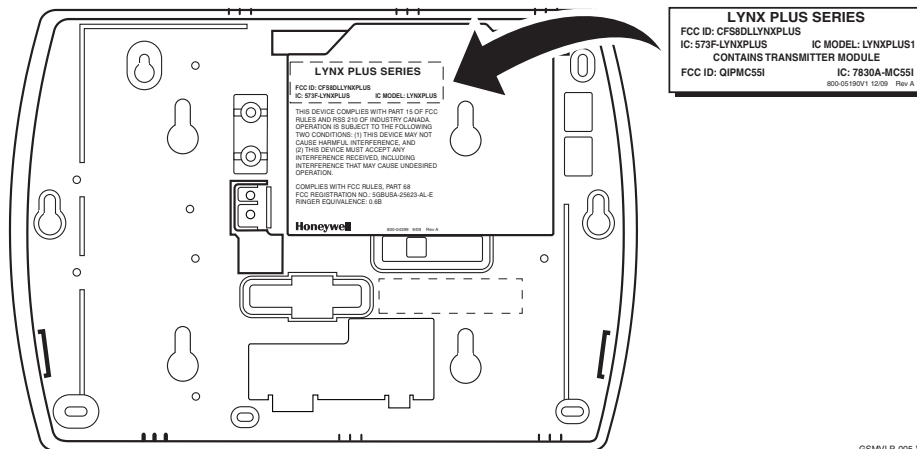

Figure 2 – FCC/IC Label location



RF Exposure

WARNING: The antenna(s) used for this transmitter must be installed to provide a separation distance of at least 20 cm from all persons and must not be co-located or operating in conjunction with any other antenna(s) or transmitter.

2. Release the control's front case assembly from the rear case by depressing the two locking tabs at the top of the unit with the blade of a medium size screwdriver (refer to Figure 3).

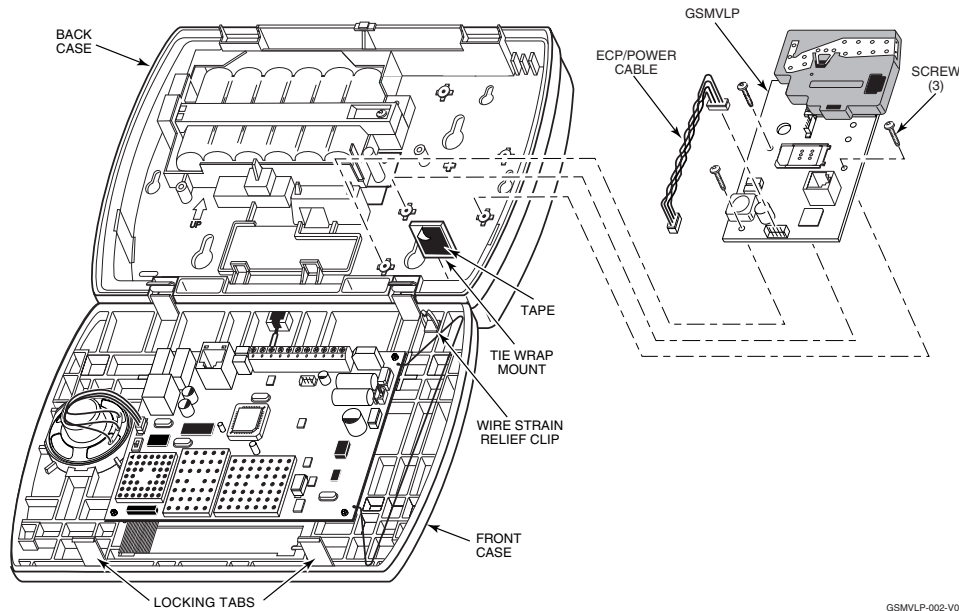

Figure 3 – Installing the GSMVLP Module

3. Install the control in accordance with the appropriate Installation Instructions.
4. Install the GSMVLP into the control's back case and secure it with the three provided screws. Refer to Figure 3.



Do not block the ventilation slots in the case when installing the tie wrap mount.

5. Remove the backing from the tape on the provided tie wrap mount. Install the tie wrap mount in the lower right corner of the back case as shown on Figure 3.
6. Connect the provided ECP/power cable between the GSMVLP module and the PC board and route the cable as shown in Figure 4. This cable provides DC power and ground for the module and ECP connections.



For best radio performance, the wires, ECP/power cable, battery and shielded audio cables must be routed as shown in Figure 4.

7. Make the wiring connections and install the control in accordance with the appropriate Installation Instructions. Ensure that the ECP/power and battery cables are routed through the routing tunnels and/or the strain relief clip as shown in Figure 4.
8. Secure the wiring with the provided tie wraps as shown in Figure 4.
9. Program the GSMVLP. Refer to the Programming the GSMVLP Module section.

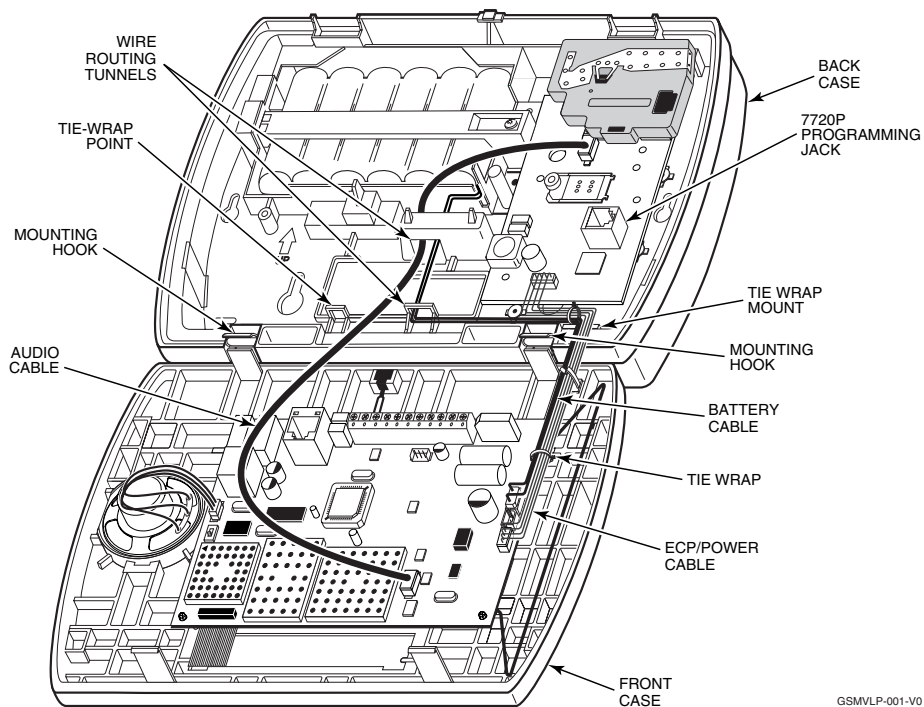

Figure 4 – GSMVLP Wiring Connections and Routing

10. Connect the provided shielded audio cable between the GSMVLP module and the PC board and route the cable as shown in Figure 4.
11. Snap the control front assembly to the back plate.

Programming the GSMVLP Module

The GSMVLP Module can be programmed through the following methods:

- The AlarmNet Direct website
- Use of a 7720P Programming Tool

Using the AlarmNet Direct website

To program the module via the website (if you are already signed up for this service), go to: <https://services.alarmnet.com/AlarmNetDirect/userlogin.aspx>

If you are not signed up for this service, click on “Dealer Sign-Up”. Log in and follow the on-screen prompts. Please have the following information available when programming the module:

1. Primary City ID (two-digit number)
2. Primary Central Station ID (two-digit hexadecimal number)
3. Primary Subscriber ID (four-digit number)
4. MAC ID and MAC CRC number (located on the outside of box and on the GSMVLP)
5. After programming is complete, you must transfer the data to the GSMVLP and the module must be registered. Refer to the Registration section for further instructions.

Using a 7720P Programming Tool

Connect the 7720P Programming Tool as shown in Figure 5. The GSMVLP powers the 7720P Programming Tool via the programming jack. Each key of the 7720P has two possible functions: a normal function and a Shift function.

- To perform a normal key function, simply press the desired key.
- To perform a Shift function, press the [shift] key, and then press the appropriate key.

The prompts in this document reflect use of the 7720P Programming Tool. Table 1 lists each normal and shift key function.

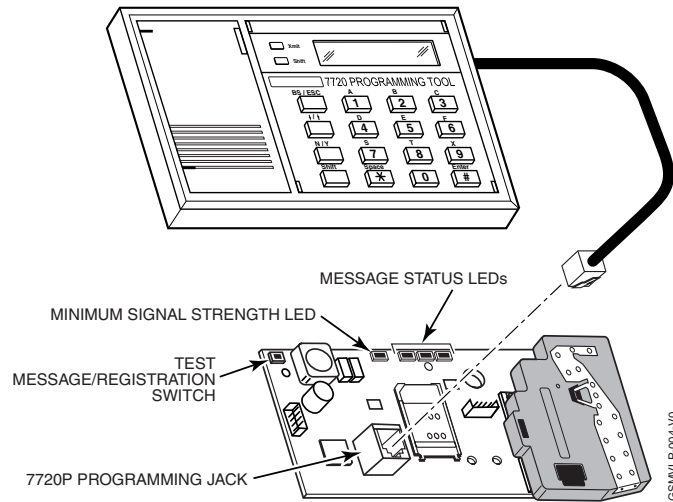

Figure 5 – 7720P Connection

Table 1 – 7720P Normal and Shift Key (shift LED lit) Functions

| KEY | NORMAL KEY FUNCTION | SHIFT KEY FUNCTION |
|---------|--|---|
| BS/ESC | [BS]: Press to delete entry | [ESC]: Press to quit program mode; also can reset programming defaults* |
| ↓/↑ | [↓]: Scroll down programming | [↑]: Scroll up programming |
| N/Y | [N]: Press for "NO" answer | [Y]: Press SHIFT-Y for "YES" answer |
| SHIFT | Press before pressing a SHIFT key function. Will light SHIFT LED. LED goes out once a key is pressed. Press again for each SHIFT function desired. | |
| 1/A | [1]: For entering the number 1 | [A]: For entering letter A |
| 2/B | [2]: For entering the number 2 | [B]: For entering letter B |
| 3/C | [3]: For entering the number 3 | [C]: For entering letter C |
| 4/D | [4]: For entering the number 4 | [D]: For entering letter D |
| 5/E | [5]: For entering the number 5 | [E]: For entering letter E |
| 6/F | [6]: For entering the number 6 | [F]: For entering letter F |
| 7/S | [7]: For entering the number 7 | [S]: For entering letter S |
| 8/T | [8]: For entering the number 8 | [T]: For entering letter T |
| 9/X | [9]: For entering the number 9 | [X]: For entering letter X |
| SPACE | [SPACE]: For scrolling option list | No SHIFT function |
| 0 | [0]: For entering the number 0 | No SHIFT function |
| #/ENTER | [#/ENTER]: Starts programming mode; Press to accept entries | No SHIFT function |

*Active only when the "Exit Programming Mode" prompt is displayed.

Programming Conventions

Programming is accomplished by answering a series of prompts (questions). Most prompts require only a [Y]es or [N]o response, while others require a numerical response (ID numbers, etc.).

The current value is displayed on the second line in parentheses (). A "?" indicates an invalid entry.

Use the [ENTER] key to accept the current entry and proceed to the next prompt. If the entered value is invalid, pressing [ENTER] re-displays the prompt; the next prompt is not displayed until a valid answer is entered.

Use the up/down arrow keys to scroll through the programming questions without changing any values. Press the [ESC] key to go to the end of the list of questions.

PROGRAMMING

ECP Mode Programming

The GSMVLP supports ECP messaging to communicate with the control panel. Lynx Plus Series/ReadyGuard Plus Series control send Contact ID format alarms to the GSMVLP directly on the 4-wire console bus. Refer to Table 2 for GSMVLP programming and follow the prompts.

Press the [ENTER] key to begin programming.

| | |
|--|---------------------------------------|
| NOTE: The central station can remotely block access to local device programming. If this has been done, the following prompt appears: | Access to Prog Mode Denied |
|--|---------------------------------------|

Table 2 – Programming the GSMVLP Module

NOTE: The default programming values are listed in the prompts below.

| | PROMPTS | ENTRY | OPTIONS | DESCRIPTION |
|---|----------------------------|-------|------------------------------|---|
| 1 | Strt Prog Mode? (Y/N)_ | | [Y], [N] | Enters programming mode. |
| 2 | Enter Password | | [0-9, A-F, N, S, T, X, Y] | If a password has been previously assigned, this prompt appears. Enter a 4-digit password (0-9, A-F, N, S, T, X, Y). The next prompt appears. |
| 3 | Program Device? (Y/N)_ | | [Y], [N] | To begin programming the module, press [Y] and go to Prompt 9: "Device Mode." To create a password if none has been assigned, press [N] and go to Prompt 4: "Create Password?" To change an existing password, press [N] and go to Prompt 5: "Change Password?" |
| 4 | Create Password? (Y/N)_ | | [Y], [N] | Passwords can be used to protect account and programming information. If no password has been assigned, this prompt appears after pressing [N] at the "Program Device?" prompt. If a password is desired, press [Y] and go to Prompt 6: "Enter Password." |

| | PROMPTS | ENTRY | OPTIONS | DESCRIPTION |
|---|----------------------------|-------|------------------------------------|---|
| 5 | Change Password? (Y/N)_ | | [Y], [N] | If a password has already been assigned, this prompt appears after pressing [N] at the "Program Device?" prompt. Press [Y] if you want to change the password. NOTE: To clear an existing password, without entering a new one, answer [Y] to the "Change Password?" prompt, then press the [Enter] key when prompted for the new password and its confirmation. |
| 6 | Enter Password | | [0-9, A-F, N, S, T, X, Y] | This prompt is displayed if [Y] was pressed in Prompt 4 or 5. Enter a 4-digit password (0-9, A-F, N, S, T, X, Y). |
| 7 | Verify Password | | [0-9, A-F, N, S, T, X, Y] | Re-enter the password as confirmation. If the password doesn't match the first entry, the following is displayed followed by the "Exit Prog. Mode?" prompt: Verify Not OK PSWD not created Otherwise, the "Exit Prog. Mode?" prompt is displayed directly. |
| 8 | Exit Prog. Mode? (Y/N)_ | | [Y], [N] [ESC] | Exits program mode. Press [N] to go back to Prompt 3. Press [ESC] to load factory defaults. Refer to the <i>Exiting Programming Mode</i> paragraph in this section. |
| 9 | Device Mode (ECP)_ | | • ECP • 4204 Emu • Two 4204s | Press the [space] key to scroll through the modes of operation. Press [ENTER] to select ECP mode. IMPORTANT NOTE: Do not select any other mode. |

Setting up the Multi-Mode Feature

Multi-Mode enables users to receive e-mail notification of system events. Since the communication device is emulating a 4204 or two 4204 modules, there is no additional hardware to install.



E-mail notification is intended as a convenience for the user, and does not replace Central Station reporting of critical events (alarms, troubles, etc.).

Enabling the Multi-Mode Feature

- Multi-Mode must be enabled during account programming on the AlarmNet Direct website by selecting "Enabled" at the Multi-Mode prompt.

Configuring Multi-Mode

The communication device emulates one or two standard 4204 relay modules for purposes of triggering events for sending e-mail reports. If "4204 Sourced" is selected, you must enable Multi-Mode Address 6 or 7 in Lynx Plus/ReadyGuard Plus Series Programming Field *86. If "2-4204 Sourced" is selected, you must enable both.

When "4204 Sourced" is selected, the user can be notified of up to four events, and when "2-4204 Sourced" is selected, the user can be notified of up to eight system events. The Multi-Mode Address must match the address of the e-mail trigger module enabled in the Lynx Plus/ReadyGuard Plus Series control panel in Field *86.

Events used to send e-mail messages are defined on the Honeywell Total Connect website, and must correspond to (e-mail) event triggers programmed in the control panel as events 09-16 in field *80 Device Programming Menu Mode.

| | PROMPTS | ENTRY | OPTIONS | DESCRIPTION |
|----|------------------------|-------|--|---|
| 10 | Multi Mode (Disabled)_ | | <ul style="list-style-type: none"> • Disabled • 4204 Sourced • 2-4204 Sourced | <p>Enable if you want system events sent by e-mail to the user. Select "4204 Sourced" to send up to four events, or "2-4204 Sourced" to send up to eight events.</p> <p>Disable for normal alarm processing and go to Prompt 12 "Primary City ID" prompt.</p> |
| 11 | Multi Mode Addr (12) | | [01-30] | <p>NOTE: This prompt will only appear if the Multi-Mode feature has been enabled.</p> <p>This address must be programmed if using the Multi- Mode (e-mail notification) feature. The device address must be unique from the normal Device Address and the Keypad Address used for Remote Access.</p> <p>Multi-Mode uses address(es) 6 and/or 7, which must also be enabled in the control panel.</p> |



1. Account information is provided by the central station administrator.
2. The Lynx Plus Series/ReadyGuard Plus Series Controls do not support second account reporting.

| | | | | |
|----|-----------------------|--|-------------|---|
| 12 | Primary City ID (??)_ | | [01-99] | Enter the 2-digit primary city ID, 01-99 (decimal). |
| 13 | Primary CS ID (??) | | [01-FE] | Enter the 2-digit primary central station ID number, 01-FE (HEX). |
| 14 | Primary Sub ID (????) | | [0001-9999] | Enter the 4-digit subscriber account number, 0001-9999 (decimal). |
| 15 | Device Address (03)_ | | [01-30] | <p>The GSMVLP communicates with the panel as a Long Range Radio (LRR) device. Enter ECP device address 03.</p> <p>NOTE: When programming the control, enable the LRR output.</p> |

Setting up the Remote Access Feature

Remote Access enables the user to remotely control the security system using a standard web browser.

Enabling Remote Access:

- Remote Access must be enabled during account programming on the AlarmNet Direct website by selecting "Enabled" at the Remote Access prompt.
- A keypad address of "1" must be enabled in the GSMVLP in order for the device to communicate with the control panel.

Selecting the User Interface:

This option is selected during account programming from the AlarmNet Direct website and follows the "Keypad Address" prompt. In the "Keypad Type" prompt, select "LYNX Keypad".

| | PROMPTS | ENTRY | OPTIONS | DESCRIPTION |
|----|---------------------------------|-------|---|--|
| 16 | Remote Access Y/N (N)_ | | [Y], [N] | Press [Y] to allow the end user to access their system via a website. Availability of this service is controlled by the dealer via the web-based programming tool on the AlarmNet Direct website. |
| 17 | Keypad Address (28)_ | | [01-30] | NOTE: This prompt will only appear if the Remote Access feature has been enabled. Must be programmed if using the Remote Access feature. Enter the appropriate device address. NOTE: This address must be set to "1". |
| 18 | Supervision (24 Hours)_ | | <ul style="list-style-type: none"> • 30 Day • 24 Hour • None | The AlarmNet network must hear at least one supervisory message from the module during this supervision period; otherwise, AlarmNet notifies the central station that a communication failure has occurred. (If the supervision period is changed after registration, you must re-register the module.) Press the [space] key to scroll through choices. UL NOTE: Must be 24 hour. |
| 19 | Old Alarm Time (10 Minutes)_ | | <ul style="list-style-type: none"> • 10 Minutes • 15 Minutes • 30 Minutes • 1 Hour • 2 Hours • 4 Hours • 8 Hours • 12 Hours • 24 Hours | The old alarm time sets how long an undeliverable alarm is retried for delivery to the central station. If the message is not validated, it is retried until the old alarm time is reached or the message is validated. Press the [space] key to scroll through choices. UL NOTE: Must be 10 minutes. |
| 20 | GSM Fit Time (00 mins)_ | | [01-99] [00] = not used | In the event the module detects a communication path failure, enter the time delay (in minutes) before the module notifies the control panel with a trouble message. The control panel can then notify the central station. UL NOTE: Must be one (01) minute. |

| | PROMPTS | ENTRY | OPTIONS | DESCRIPTION |
|----|-------------|-------|----------------------------|---|
| 21 | Review? Y/N | | [Y] = review [N] = exit | <p>Reviewing Programming Mode Entries To review the programming options (to ensure that the correct entries have been made), press [Y]. The programming prompts are displayed again. Use the up/down arrow keys to scroll through the program fields without changing any of the values. If a value requires change, simply type in the correct value. When the last field is displayed, the "REVIEW?" prompt again appears.</p> <p>To exit the programming mode, press [N] in response to the "REVIEW?" prompt, and refer to <i>Exiting Programming Mode</i> paragraph at the end of this section.</p> |

ECP Status Codes

The GSMVLP sends status messages to the control panel to indicate general failures. The control will display "FAULT 103" if any of the events listed below should occur. In addition, the Contact ID codes (listed in Appendix A) for these conditions are sent to the central station by the module.

- GSMVLP loses communication with control panel.
- GSMVLP lost contact with AlarmNet.
- GSMVLP is not registered; account not activated.
- GSMVLP shutdown.

Exiting Programming Mode

To exit the programming mode, press [N] in response to the "REVIEW?" question. Then press [Y] to the "Exit Prog Mode?" question. Upon exiting, the message "Checking Root File TX Path" will be displayed, and the configuration file at the server is updated to log the changes made. When complete, the message "DONE" is displayed to indicate the file was successfully uploaded.



If critical configuration changes were made, such as the mode of operation, the GSMVLP will reset to ensure that the programming features are enabled.

If the file is not successfully uploaded, one of the following prompts will be displayed. Follow the steps shown below, until the upload is successful.

| Display | Description | What to do |
|----------------------------------|--|---|
| Cannot Upload Try Again? Y/N_ | GSMVLP radio not yet initialized. | Wait for RSSI LEDs to be lit. Press [Y]. |
| Failed to Update Root File! | Network problem, or you answered "N" to "Cannot Upload Try Again?" prompt. | Initiate the Force Server Update command by pressing the [0] key; refer to the <i>Programmer Keyboard Commands</i> section. |

Setting Factory Defaults

To reset the programming options to factory-default values, press [ESC] at the "Exit Prog Mode?" prompt.

Set Default?
Y/N_

Press [Y] to reset factory default values.

Press [N] to cancel this function.

If you press [Y], all programmed values are reset to the original factory settings.

IMPORTANT NOTE: THIS WILL ERASE ANY PASSWORD THAT MAY HAVE BEEN ENTERED.

After pressing [Y], the Create Password prompt appears (see Programming step 4).

REGISTRATION

Registering the GSMVLP

Once you have initialized and programmed the GSMVLP, it must be registered to enable the account. An unregistered GSMVLP is indicated on the Status Display as: Status lit, Message slow blinking, and Fault not lit.



Figure 6 – Unregistered GSMVLP Status Display In Normal Operation

Throughout this document, the following key is used to describe LED state:

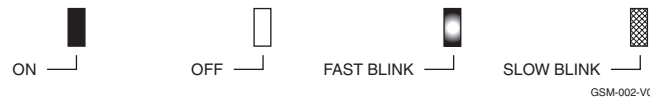

Figure 7 – LED Key

Upon completion of the registration process, a GSMVLP transmits a registration message and receives a registration validation indicating that the account is now enabled. Wait for the "Registration Success" message to appear.



The "Registration Success" message is only displayed when the 7720P Programming Tool is used for registration.

You can register the GSMVLP by one of the following methods:

- Through the AlarmNet Direct website
- Through the use of the Tamper Switch
- Through the use of a 7720P Programming Tool
- By phone

Registering through AlarmNet Direct Website

To register the module via the website (if you are already signed up for this service), go to:
<https://services.alarmnet.com/AlarmNetDirect/userlogin.aspx>.

Log in and follow the on-screen prompts.

If you are not signed up for this service, click on “Dealer Signup” from the login screen to gain access to the Honeywell web-based programming.

You will be instructed how to proceed upon completing the sign-up form. Only one sign-up per dealer is required. Once an initial user is established, additional logins may be created by that user.

NOTE: Central Stations sign up by contacting AlarmNet Administration at 800-222-6525 option 3.

Please have the following information available when programming the device:

1. Primary City ID (two-digit number)
2. Primary Central Station ID (two-digit hexadecimal number)
3. Primary Subscriber ID (four-digit number)
4. MAC ID and MAC CRC number (located on outside of box and on label inside module) or MIN number of the device you are replacing.

Once module is registered, you may log out of the AlarmNet Direct website.

Using the Test Message/Registration Switch

Initiate the registration sequence by clicking the Test Message/Registration Switch three times.

You can monitor the registration process by viewing the Status Display. The Message (yellow) LED and the Status (green) LED will blink slowly in unison while registration is in progress.

Once the registration has been completed successfully, the GSMVLP enters normal operating mode; the Status (green) LED goes out and the Message (yellow) LED is lit to indicate that the power-on / reset message is waiting to be sent. This message will appear at the receiving station as “E339 803”. The description may read “Trouble – Exp. Mod. Reset”. If registration is not validated within 90 seconds, the GSMVLP times out, and the (green) LED will be lit (solid).

Using the Programming Tool

The interactive registration feature allows the installer to register the GSMVLP through a series of keyboard commands on the 7720P Programming Tool. This method of registration lets the installer monitor the registration process.

Registering ...

Once the installation is complete, press the [↑] key on the 7720P. The registration message is sent and the unit waits for the acknowledgment.

**Registration
SUCCESS**

If this is a new installation and the city, central station, and customer numbers have been correctly entered, the GSMVLP is registered and this message is displayed. The GSMVLP is now in full service and available for alarm reporting to the central station.

Possible Errors

**Registration BAD
Timed Out**

Displayed if no response to the registration request is received.

**Registration BAD
Pri Sub ID BAD**

Indicates the city, central station, or customer number for the labeled account(s) is not accepted. The ID information was either entered in error, or the central station failed to pre-authorize programmed ID numbers with AlarmNet customer service.

**Registration BAD
Pri ID – Need PIN**

Displayed if this is a repair/replacement, or an error was made in programming the Primary account information of GSMVLP for an existing account. This prompt appears for 2 seconds. See the *Replacing an existing module* section below for further displays.

Replacing an existing module using the programming tool

Enter PIN#

This prompt appears after pressing the **down arrow** [↓] on the 7720P. Enter a 4-digit alphanumeric PIN number provided by your central station, your dealer or an authorized AlarmNet representative.

NOTE: If you are replacing an existing "C Series" radio, you can enter the last four-digits of the "C Series" MIN number.

Press the [ENTER] key.

Registering ...

The registration message is sent and the unit waits for acknowledgement.

**Registration
SUCCESS**

If the PIN is valid, the new GSMVLP is registered and the old unit unregistered. Additionally, AlarmNet sends a substitution alarm to the central station.

Registration BAD

If you entered an invalid PIN, the appropriate message is displayed depending on which account number is being replaced (see above for exact wording). The registration process is repeated.

NOTE: Each attempt causes a substitution alarm to be sent to the central station.

Register by Phone

You can register the module by calling the AlarmNet Technical Assistance Center (TAC) at 1-800-222-6525 (Option 1).

You will need the following information:

- MAC number (found on the label).
- Subscriber information (provided by the central station), including a city code, CSID, and subscriber ID.
- When instructed to do so, triple-click the Test Message/Registration switch to complete the registration.

PROGRAMMER KEYBOARD COMMANDS

Programmer keyboard commands can be used to quickly view your connectivity settings and options. Most commands require you to press the [shift] key and then the designated command key. (See the keys designated in red on the 7720P Programming Tool.)

[A]

| |
|--|
| 7845GSM x.x.xx mm/dd/yy |
|--|

Software Revision

"x.x.xx" indicates the installed software revision.

Mm/dd/yy indicates month, day and year of the revision.

Module Identification Displays

[B]

| |
|-------------------------|
| MAC xxxxxxxxxxxx |
| MAC CRC yyyy |

MAC Address

"xxxxxxxxxxxx" indicates the GSMVLP's unique identification number.

"yyyy" indicates the MAC CRC number. These numbers are found on the label on the module, as well as the label on the box. Press the [space] key to go to the next field.

Press the [backspace] key to go to the previous field.

| |
|----------------------------|
| SCID xxxxx xxxxx |
| xxxxx xxxxx |

SCID Display

Displays the identification number assigned to the SIM card (SCID) in this device.

Press the [space] key to go to the next field.

Press the [backspace] key to go to the previous field.

| |
|----------------------|
| IMEI xxxxxxxx |
| xxxxxx x |

IMEI Display

Displays the identification number assigned to the GSMVLP module in this device.

Press the [space] key to get the MAC Address.

Press the [backspace] key to go to the previous field.

[C]

| |
|------------------------|
| Mon 01 Jan 2001 |
| 05:48:39 am |

Time

Retrieves the current date and time from the AlarmNet network in Greenwich Mean Time (GMT). This display confirms that the module is in sync with network.

[D]

| |
|------------------------|
| Encryption Test |
| AES Passed! |

Encryption Test

Performs a self-test of the AES encryption algorithm.

Press the [Space] key to go to the next field.

Press the backspace [BS] key to go to the previous field.

GSMVLP Status Displays

[E]

| |
|-------------------------|
| PriRSSI GPRS REG |
| -xxxdbm x x |

GSMVLP Status Display Screen 1

PriRSSI – Primary Site RSSI level in dbm

GPRS – GPRS Service availability where “x” can be:
 “Y” if GPRS is available
 “N” if GPRS is Not available

REG – Registration status from radio module where
 “x” can be:
 N – Not Registered
 H – Registered Home
 S – Searching
 D – Registration Denied
 R – Registered Roaming
 ? – Unknown Registration State

Press the [space] key to go to the next screen.

Press the [backspace] key to go to the last screen.

| |
|-----------------------|
| Cntry Netw LAC |
| xxx xxx xxxxx |

GSMVLP Status Display Screen 2

Cntry – Country Code

Netw – Network Code

LAC – Local area code

Press the [space] key to get to the next screen.

Press the [backspace] key to go to the previous field.

| |
|-------------------------|
| Cell BaseSt Chan |
| xxxxx x xxx |

GSMVLP Status Display Screen 3

Cell – Base Station ID

BaseSt – Base Station Antenna Sector

Chan – Control Channel in use

Press the [space] key to go to the next screen.

Press the [backspace] key to go to the previous field.

| |
|-------------------------|
| Second Site RSSI |
| -xxxdbm |

GSMVLP Status Display Screen 4

Secondary GSMVLP Site RSSI level in dbm.

Press the [space] key to go to the GSMVLP Status Display Screen 1.

Press the [backspace] key to go to the previous field.

[S]

| | |
|------------|------------|
| ECP | Fit |
| | OK |

ECP Mode

Displays the mode of operation and system fault status.

[T]

| |
|----------------------|
| Test Msg Sent |
|----------------------|

Test Alarm

Sends a Test alarm to AlarmNet. Functional for a *registered* GSMVLP only. If the device is not registered, a message is displayed indicating that the command cannot be executed.

[X]

| |
|----------------------|
| Reset CPU Y/N |
|----------------------|

Reset the GSMVLP.

Pressing [N] returns to normal mode.

Pressing [Y] resets the device.

[↑]

(UP arrow)

| |
|------------------------|
| Registering ... |
|------------------------|

Registration

Registers a programmed GSMVLP with AlarmNet.

[↓]
(DN arrow)

Enter PIN#

Registration with PIN for Replacement Module

Registers a replacement GSMVLP with AlarmNet, once programmed, using the existing PIN #.

[0]

Force Server
Update?
Y/N

Force Upload of Configuration File to Server

Pressing [Y] will force the device to upload its entire configuration file to the server.

Pressing [N] cancels the operation.

NOTE: If the GSMVLP module is not initialized when you enter this command, the following screen will be displayed:

Cannot Upload
Try Later! _

Wait for the RSSI LEDs to light, indicating the GSMVLP module has completed its initialization, and try again.

[ENTER]

Strt Prog Mode?
Y/N_

Enter Program Mode

Press [Y] to enter program mode; otherwise, press [N].

APPENDIX A

SUMMARY OF LED OPERATION

GSMVLP Status Display Operation

The GSMVLP Status Display has four LEDs used to indicate message and device status (refer to Figure 5). When installed in the control, the LEDs appear in the following order from top to bottom.

- STATUS, *green*
- MESSAGE, *yellow*
- FAULT, *red*
- MINIMUM SIGNAL STRENGTH, *green*

Each LED can have four different states - ON, OFF, FAST BLINK and SLOW BLINK. Throughout this document, the key shown in Figure 4 is used to describe LED state:

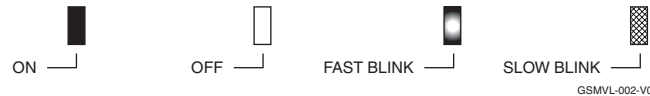

Figure 8 – LED Key

Minimum Signal Strength LED Operation

The Minimum Signal Strength LED normally displays the module's signal strength. The LED (green LED) will be lit to indicate that the minimum required signal strength for installation exists between the module and the receiving tower. Refer to Figure 9.

Table 3. Status and Signal Strength LED Operation

| LED COLOR | LED | DESCRIPTION |
|--------------------|-------------------------|--|
| GREEN | STATUS | ON – GSMVLP is NOT registered with AlarmNet. OFF – GSMVLP is registered with AlarmNet. FAST BLINK – Download session with Compass in progress. SLOW BLINK – In unison with yellow LED – Registration in progress. |
| YELLOW | MESSAGE | ON – Message transmission pending. QUICK PERIODIC BLINK - Normal FAST BLINK – Message waiting for network ACK. SLOW BLINK – In unison with green LED – Registration in progress. |
| RED | FAULT | ON – No contact with network. OFF– Normal. SLOW BLINK – Loss of communication with the panel (ECP fault). FAST BLINK – No network contact AND loss of communication with the panel. |
| GREEN | MINIMUM SIGNAL STRENGTH | ON – Minimum required signal strength is present. BLINKING – Marginal signal strength is present. OFF– Installation is not recommended. |
| ALL (of the above) | | FAST BLINK – Hardware Error. Call the AlarmNet Technical Assistance Center. |

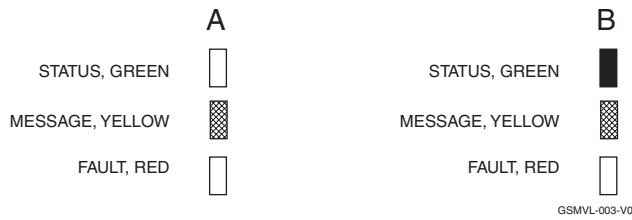

Figure 9 – A Registered GSMVLP Status Display (A) and an Unregistered GSMVLP Status Display in Normal Operating State (B)

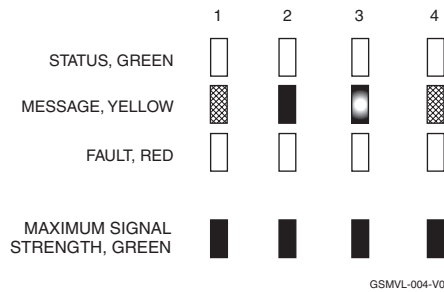

Figure 10 – LED Sequence for a Registered GSMVLP Message Transmission

CENTRAL STATION MESSAGES

The following messages are sent to the Central Station by the GSMVLP module for the conditions listed below.

Table 4 – GSMVLP Central Station Messages

| Alarm Condition | ECP Mode Alarm Code | ECP Mode Restore Code |
|----------------------------|---------------------|-----------------------|
| Power On Reset | E339 C0803 | |
| ECP Supervision | E355 C0000 | R355 C0000 |
| Communication Path Restore | | R350 C0951 |
| Test | 5555 5555 9 | |

Note: The control panel sends its own general code (E353) for a trouble condition.

GSMVLP DOWNLOADING

General Information

The GSMVLP can be used to provide high-speed up/downloading to Lynx Plus/ReadyGuard Plus Series control panels over the GPRS network via ECP communication. This allows site maintenance independent of central station monitoring, and modification to sites globally.

UL Downloading may only be performed if a technician is at the site.

GLOSSARY

AES – Advanced Encryption Standard

ECP – Enhanced Console Protocol, which is a proprietary communications bus used in Honeywell control panels for wiring additional keypads and peripheral devices; consists of a four-wire data bus (power+/-, data in/out).

GPRS – (General Packet Radio Service)

GSM – Global System for Mobile communications, which is an international standard for digital mobile phone systems used for cellular communication.

IMEI – International Mobile Equipment Identity number

MAC Address – Media Access Code; located on the module label.

SPECIFICATIONS

1. Physical

Dimensions: 5.625" x 2.25"

2. Electrical

Input Voltage: 12VDC (powered by the Lynx Plus/ReadyGuard Plus Series Control)
(Range: 5.5 VDC-12 VDC)

Quiescent Current: 40mA

Peak Current During Transmit: 650mA

- NOTES -

Honeywell

2 Corporate Center Drive, Suite 100
P.O. Box 9040, Melville, NY 11747
Copyright © 2009 Honeywell International Inc.

www.honeywell.com/security



800-04954V1 12/09 Rev A