

Honeywell

AlarmNet[®]

7845i-GSM/7845i-GSMCN

Internet Communication Module Installation and Setup Guide



**Now Supports
Remote Services**

Requires Compass Version 1.5.8.54A (or higher) for IP/GSM Downloading

Table of Contents

SECTION 1: General Information	1-1
System Overview	1-1
Introduction	1-1
General Information.....	1-1
System Features	1-2
About AlarmNet-i Internet Application	1-2
Encryption	1-2
Remote Services	1-2
Modes of Operation	1-3
ECP Mode	1-3
Zone Trigger Mode	1-3
4204 Mode and Two-4204 Mode	1-3
Module Supervision Features	1-3
Antenna.....	1-4
Specifications	1-4
Mechanical.....	1-4
Electrical	1-4
RF	1-4
Ethernet.....	1-4
Environmental.....	1-4
SECTION 2: Mounting and Wiring	2-1
Mounting the 7845i-GSM.....	2-1
Wiring the 7845i-GSM.....	2-2
Wiring for ECP, 4204 and Two-4204 Modes.....	2-2
Wiring for Zone Trigger Mode	2-3
Wiring for Module Fault Relay.....	2-4
Ethernet Connections	2-5
Power Connections and Options	2-5
Backup Battery Connection.....	2-6
Initial Power-Up Sequence	2-6
SECTION 3: Programming the 7845i-GSM	3-1
General Information	3-1
Using the AlarmNet Direct website.....	3-1
Using a 7720P Programming Tool	3-1
Using the Control Panel Programming Mode	3-2

Programming Conventions	3-2
ECP Mode Programming.....	3-2
ECP Status Codes	3-8
Alternative Modes (Zone Trigger, 4204 and Two-4204).....	3-8
Zone Trigger Mode	3-8
4204 Emulation Mode	3-9
4204 Emulation Mode Options.....	3-9
Alternative Mode Programming	3-10
Exiting Programming Mode.....	3-18
Setting Factory Defaults	3-19
SECTION 4: Registration	4-1
Registering the 7845i-GSM.....	4-1
Register through AlarmNet Direct Website	4-1
Register using the Tamper Switch.....	4-2
Register using the Programming Tool	4-2
Replacing an existing module using the programming tool.....	4-3
Register by Phone.....	4-4
SECTION 5: Programmer Keyboard Commands	5-1
Programmer Keyboard Commands	5-1
Module Identification Displays	5-1
GSM Status Displays	5-2
System Status Displays	5-2
SECTION 6: Registration	6-1
Running Network Diagnostics on the 7845i-GSM.....	6-1
Appendices	A-1
Appendix A : Summary of LED Operation.....	A-1
7845i-GSM Status Display Operation	A-1
Network Connectivity Display	A-3
Signal Strength (RSSI) / Mode and Status LEDs	A-4
Mode and Status Indicator Switch.....	A-4
Appendix B : Central Station Messages.....	B-1
Appendix C : IP Downloading	C-1
General Information	C-1
Direct Wire Setup	C-1
Appendix D : Glossary	D-1
Summary of Connections Diagram.....	Inside Back Cover

General Information

In This Section

- ◆ *System Overview*
 - ◆ *System Features*
 - ◆ *About AlarmNet-i Internet Application*
 - ◆ *Encryption*
 - ◆ *Remote Services*
 - ◆ *Modes of Operation*
 - ◆ *Module Supervision Features*
 - ◆ *Specifications*
-

System Overview

Introduction

UL The 7845i-GSMCN has not been evaluated by UL.

Congratulations on your purchase of Honeywell's 7845i-GSM/7845i-GSMCN combination Internet/GSM communication module (henceforth referred to as 7845i-GSM). It represents the latest and most innovative communication technology for the security industry and uses the most sophisticated encryption to ensure the highest level of security for your customer.

Not only will alarms and other messages be transmitted via this module, the 7845i-GSM provides uploading/downloading capability of Honeywell's control panel data (when connected), over the Internet or via the AlarmNet-G network, using GSM (Global System for Mobile) technology when the internet is not available.



The 7845i-GSM module requires an AlarmNet-I account. For new installations, please obtain the account information from the central station prior to programming this module. For replacement installations, the AlarmNet-i account is created automatically when the module is registered (based on the existing "C Series" account).

General Information

Honeywell's 7845i-GSM Internet communication module leverages Internet service (when service is available) and transparently switches to GSM service when Internet service is not available. When both services are unavailable, the 7845i-GSM module provides a third way to communicate by sending a transmission via SMS (Short Message Service) also known as a text message.

In normal operation (with Internet connectivity), the 7845i-GSM communicates from your customer's network connection to the Honeywell Network Operations Center, (NOC) via the AlarmNet-i network. The NOC receives data and routes the information to the Central Station of your choice, based on the account number you assign to the module. Note that your Central Station needs to give you the account number. The same account number is used for both Internet and GSM transmissions. If your current Central Station is capable of receiving signals from the Honeywell NOC, they are capable of receiving signals from the 7845i-GSM module.

If, for some reason, Internet connectivity is not available, (for example, your customer's ISP is off line or disconnected), the 7845i-GSM will transmit signals via the AlarmNet-G (GSM) cellular network, which uses the GPRS (General Packet Radio Service) to complete these transmissions. These transmissions are sent to the Honeywell NOC and then forwarded to your Central Station exactly the same way as if they were received via the Internet.

If the Internet AND GPRS (part of the GSM cellular network) are both unavailable, the 7845i-GSM will attempt to send the transmission via SMS (Short Message Service), also known as a text message. If all three methods fail, the message will not be sent via this device.

UL

A listed DACT must be employed as the primary communication device in UL commercial burglar alarm installations.

System Features

Basic features of the 7845i-GSM include:

- Easy CAT-5 10 BaseT connection to a hub or router
- Installs behind firewalls without compromising network security
- Supports dynamic or static IP addressing
- Quick connection to compatible Honeywell series control panels
- Simple programming using a 7720P programming tool
- Reports fire, burg, and status messages via the Internet
- Reports messages via AlarmNet-G as backup to Internet reporting
- Allows uploading and downloading of control panel data over the Internet.
- Supports remote control of alarm systems via Remote Services feature.

About AlarmNet-i Internet Application

AlarmNet-i is a fully encrypted, secure method of delivering alarm messages from a protected premise to an AlarmNet equipped central station. An Internet Communicator Module transmits status, supervisory, and alarm messages to the AlarmNet Control Center using a broadband Internet connection.

The AlarmNet Control Center identifies, validates, and forwards the messages to the appropriate AlarmNet central station. AlarmNet-i has an unlimited account capacity.

Encryption

The 7845i-GSM supports private key encryption. Private key encryption means that both the sender and the receiver know the KEY used to encrypt the data. Each device produced by Honeywell is loaded with a globally unique identifier called a MAC number, and a large random number or KEY. This KEY and MAC number are also stored in the AlarmNet servers. When a device contacts AlarmNet, it sends the MAC number in the clear followed by the message that is encrypted using the KEY data. The server looks up its copy of the KEY based on the MAC number and uses that KEY to decrypt the message.

The 7845i-GSM uses 256 bit AES (Rijndael) encryption (which is required for certain government installations). The AlarmNet-i AES Encryption Software Module Version 1.0 contained in the Honeywell products has NIST approval. Listings for this approval can be found at <http://csrc.nist.gov/cryptval/aes/aesval.html> Certification number 127.

Remote Services

Honeywell now offers a new series of web based services that provides consumers with the ability to communicate with their security system remotely in a number of ways. These new web services will allow users to:

- Access their security system from a computer via a website (Remote Access feature)
- Receive email and text message notifications of system events (Multi-Mode feature)
- Perform system functions and receive confirmations using text messages (SMS feature)

Dealers will initially enroll their customers for web services during account programming through the AlarmNet Direct website. The features that can be enabled include Remote Access and Multi-Mode. Once enabled, the specific programming fields associated with these

features can be programmed into the communications device either remotely using the AlarmNet Direct website or locally using the 7720P local keypad programming tool.

UL Remote Access and Multi-Mode have not been evaluated by UL.

Modes of Operation

The 7845i-GSM provides four modes of operation so it can be used with various types of control panels, as summarized below:

ECP Mode

- This mode is for use with Honeywell controls that support LRR-ECP communication, and provides 2-way communication with the control using ECP messaging
- The control treats the module as a Long Range Radio (LRR) device, so program the control accordingly, including setting the module's proper LRR device address
- Reports are sent in Contact ID format
- The module also supports two hardwire zone trigger inputs (zones 6 and 7)

Zone Trigger Mode

- This mode is for use with controls that do not support LRR-ECP communication nor 4204 Relay Modules
- The module provides six input zones
- Each zone can be configured for +V, -V, or EOLR triggering
- Each zone can be programmed for inverted operation, delayed reporting, and restoral reporting
- Zone 1 input can distinguish between pulsed and steady signals and report fire or burglary alarms respectively
- Zone 1 can also be programmed to report LYNX panic (if used with LYNX control)
- Reports are sent in ADEMCO High-Speed format

4204 Mode and Two-4204 Mode

- This mode is for use with Honeywell controls that do not support LRR-ECP communication, but that do support 4204 Relay Modules
- The module connects to the control's keypad terminals
- The control treats the module as 4204 Relay Module(s), so program the control accordingly, including setting the module's proper 4204 device address
- 4204 mode provides up to four zone inputs, plus two optional trigger zones, depending on options programmed
- Two-4204 mode provides up to eight zone inputs, depending on options programmed
- Each 4204 zone can be programmed for delayed reporting and restoral reporting
- Reports are sent in ADEMCO High-Speed format

Module Supervision Features

The 7845i-GSM provides the following types of supervision and module fault detection:

- Network communication failure: In the event the AlarmNet network does not hear a supervisory message from the module within a specified time ("Supervision" option), AlarmNet notifies the central station of a communication failure.
- Communication path failure: In the event the module detects a communication path failure, the control panel can be notified of a trouble condition with the module after a specified time has elapsed ("Notify Panel Of" option).
- Fault output: Terminal 11 can serve as a fail-safe trigger for module fault conditions.
- If used, the fault relay will trip when the following conditions occur: tamper*, power loss*, low battery*, battery charger fault*, loss of network connectivity*, the device is not registered and the device is remotely disabled by AlarmNet.

* Alarm reporting for the noted condition must be enabled for it to trigger the fault relay.

- Primary power loss and low battery conditions (“Pwr Loss Rpt,” “Low Bat Rpt” options).
- Cover tamper condition (“Tamper Rpt” option).

Antenna

The 7845i-GSM comes equipped with an internal antenna. This feature provides additional security to the installation by making the device tamper resistant.



AMPS antennas, such as the 7825-OC antenna, cannot be used with this product.

Specifications

Mechanical

Dimensions: 8.4" x 8.0" x 1.5"

Weight: 2.4 lbs., with battery

Electrical

Input Power: 9VAC, 15VA transformer, Honeywell part number 1332/1332CN in Canada (included)

Backup Battery: 6V, 3.1AH, Honeywell part number K14139, (included)

Current Drain: 65mA average standby, 500mA peak transmit

Fault Relay Output: Open collector, 12VDC, .25W max.

Input Trigger Levels: (V+) 2V – 14V

(V-) 0V – 1V

RF

Transceiver Type: Tri-Band GSM/GPRS Class 10

Modulation: GMSK

Antenna: Internal GSM quad-band antenna 1.3 dBi gain

Band	Transmission Frequency (MHz)	Transmit Power (dBm)	Receive Frequency (MHz)	Receive Sensitivity (dBm)	Number of Channels	Channel Spacing (MHz)	Duplex Separation (kHz)
GSM 850	824-849	33	869-894	-107	124	200	45
GSM 1800	1710-1785	33	1805-1880	-106	374	200	95
GSM 1900	1850-1910	33	1930-1990	-105.5	299	200	80

Ethernet

Network Standard: IEEE 802.3u compliant

Data Rate: 10Base-T / 100Base-T with auto detect

Ethernet Cable: Cat. 5 (min), MDI/MDI-X auto crossover

Environmental

Operating temperature: -20° to +55°C

Storage temperature: -40° to +70°C

Humidity: 0 to 95% relative humidity, non-condensing

Altitude: to 10,000 ft. operating, to 40,000 ft. storage

Mounting and Wiring

In This Section

◆ Mounting the 7845i-GSM

◆ Power Connections and Options

◆ Wiring the 7845i-GSM

Mounting the 7845i-GSM

The 7845i-GSM must be mounted **indoors**. To mount the 7845i-GSM, see *Figure 1* and complete the following steps:

1. Unpack the 7845i-GSM and detach the case back by pushing up into the two tabs located at the bottom of the 7845i-GSM module with the blade of a screwdriver while pulling the case back and case front apart.
2. Temporarily connect the 7845i-GSM to the AC transformer, supplied.
3. Choose the installation site with the **best signal strength** by observing the signal strength (RSSI) bar graph (refer to *Appendix A* for information about signal strength and status indications). Signal strength should be within 3-5 bars. The best signal strength is usually found at the highest point in the building, near a window. Unplug the transformer.

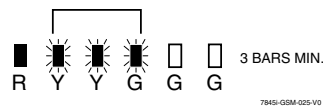

4. Locate the case back over the mounting surface such that the opening in the case back is aligned with the wire/cable access opening (in the mounting surface) while passing the wires/cable through the opening in the case back, or through the removable knockouts located on the bottom of the back cover.
5. Secure the case back to the mounting surface using four screws (supplied).
6. When all wiring is completed, attach the case front of the 7845i-GSM to the case back. Attach the top first then press the bottom section inward until it snaps into place. Secure bottom using cover securing screw (supplied) as shown below, (required for UL installations).

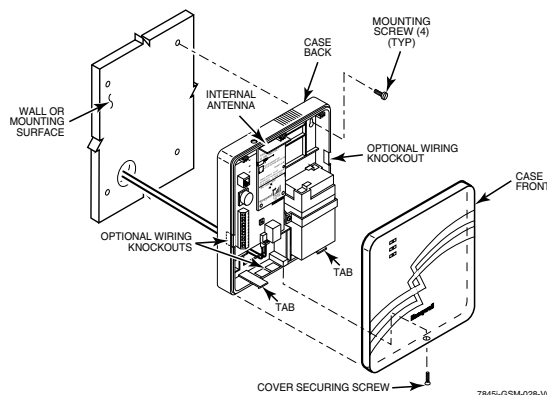

Figure 1. Mounting the 7845i-GSM



Unshielded, 22 AWG cable is recommended for 7845i-GSM power/data wires

Wiring the 7845i-GSM

Wiring for ECP, 4204 and Two-4204 Modes

Most Honeywell ADEMCO control panels support LRR-ECP data communication, (e.g., VISTA-10P, VISTA-15P, VISTA-20P, LynxR-I, VISTA-128BP and VISTA-128FBP). However, there are some panels that do not. Check the Installation and Setup Guide for the control panel you are using to see if it supports ECP communication.

Connect the 7845i-GSM to a compatible Honeywell VISTA control panel's ECP terminals, in parallel with keypads and other peripheral devices such as RF receiver, VIP module, etc. Wire length/gauge limitations are the same for the module as they are for keypads and other peripheral devices. To wire the module for ECP or 4204 modes, see *Figure 2* and make the following connections:

Table 1. Wiring connections for ECP or 4204 modes

7845i-GSM	Control
Terminal 3 V+	+12 V Aux
Terminal 4 GND	Ground
Terminal 5 Data In	Data Out
Terminal 6 Data Out	Data In

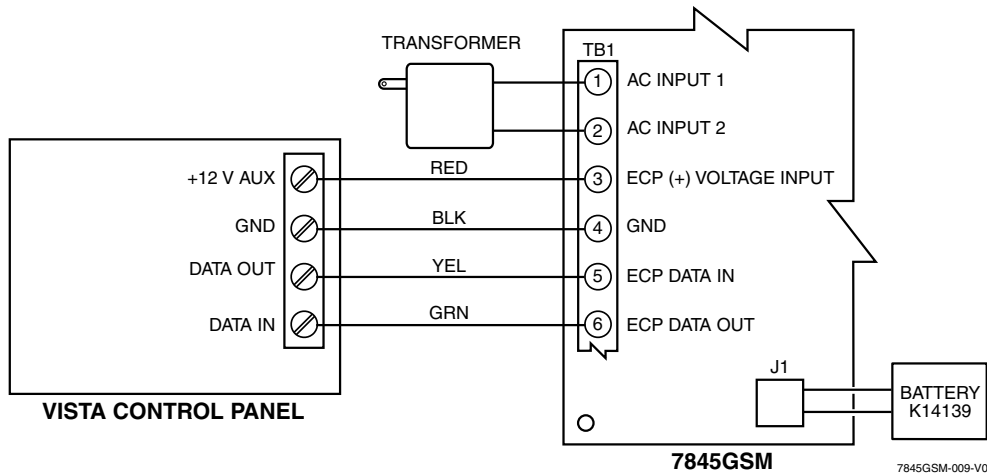

Figure 2. Wiring a VISTA for ECP Mode or 4204 Modes

To install a 7845i-GSM with a LynxR-I Security System, wire the devices as shown in *Figure 3*. Refer to the LynxR-I Installation and Setup Guide.

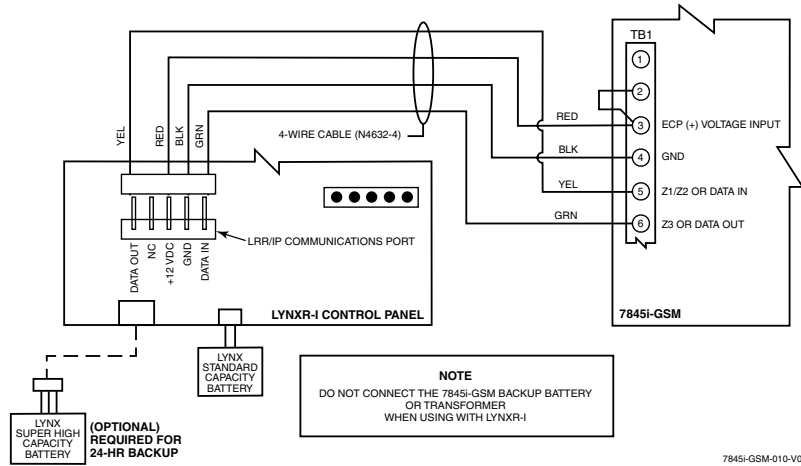

Figure 3. Wiring a LynxR-I for ECP Mode

Wiring for Zone Trigger Mode

To trip a zone on the 7845i-GSM in V+ trigger mode, the positive triggering voltage from the control panel must be within 2.0V-14V.

Trigger levels above this range may cause permanent damage to the unit.

Trigger levels below this range result in unreliable operation.

To trip a zone on the 7845i-GSM in V- trigger mode, the negative triggering voltage must be less than 1.0V.

NOTE: LynxR and LynxR-EN have a designated trigger for V- trigger.

Connect a wire from the triggering source (bell output, voltage trigger, etc.) of the control panel to the zone input of the module, and connect a common ground between the module and control panel.

UL The configurations shown in Figures 4 and 5 have not been evaluated by UL.

Examples of zone connections are shown below:

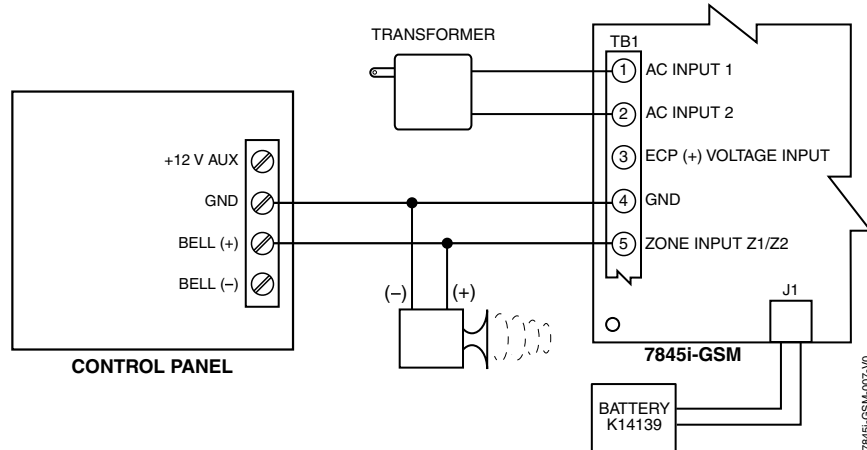

Figure 4. Wiring the 7845i-GSM Zone 1 Input for a Positive (+) Triggered Bell Output

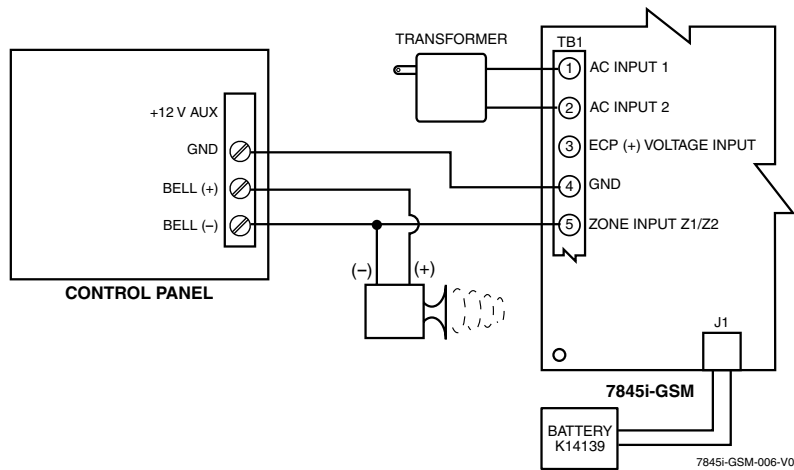

Figure 5. Wiring the 7845i-GSM Zone 1 Input for a Ground (-) Triggered Bell Output

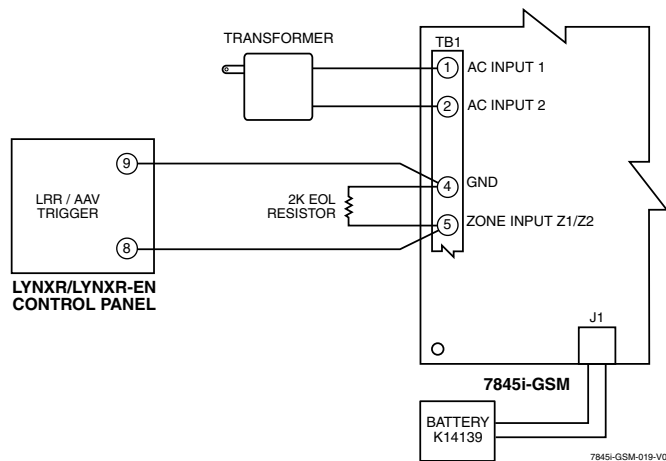

Figure 6. Wiring the 7845i-GSM Zone 1 Input to a LynxR Trigger Output

Wiring for Module Fault Relay

You may wire and program the module's fault output trigger for fail-safe mode (see the question "FLT REL ON Y/N").

To sense a module fault at the control panel, make connections as shown in *Figure 7*, including the proper EOL resistor required by the control.

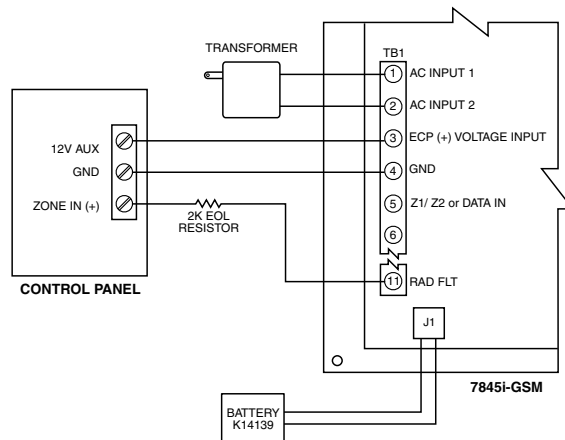

Figure 7. Wiring the 7845i-GSM to Trip a Control Panel Zone for Normally Closed Fault

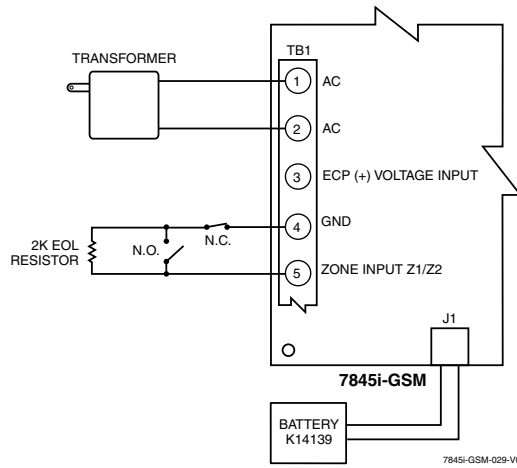

Figure 8. Wiring the 7845i-GSM Zone 1 Input for EOL Supervised N.O./N.C. Triggers

Ethernet Connections

UL

1. For UL installations, the Cat. 5 Ethernet connection between the 7845i-GSM and the router cannot exceed 12 feet with both the 7845i-GSM and the router located within the same room.
2. Use a Listed cable/DSL router suited for the application.

Connect one end of the Ethernet cable (Category 5) to the 7845i-GSM’s RJ45 Ethernet connector and the other end to the cable/DSL router as shown in Figure 9.

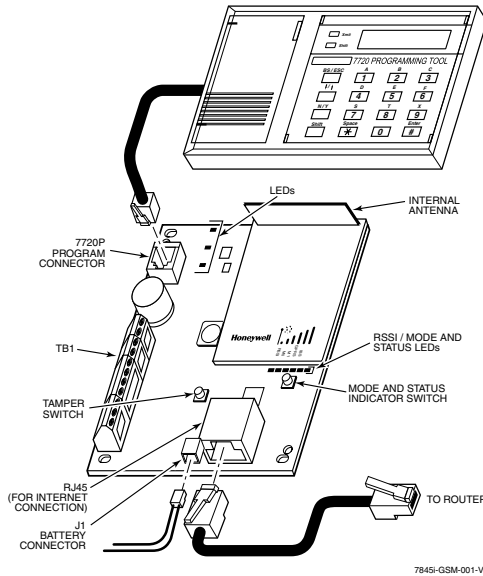

Figure 9. Ethernet Connections

Power Connections and Options

Primary power for the 7845i-GSM is provided by the AC plug-in transformer. For ECP communication, you must also connect the +12VDC AUX voltage output of the control panel (9.6V-13.8V typical) (see Figure 10). In the case of the LynxR-I, primary power is supplied by the LynxR-I unit through the LRR/IP communication port.

In all installations, TB1-4 GND must be connected to ground (GND) on the control panel.

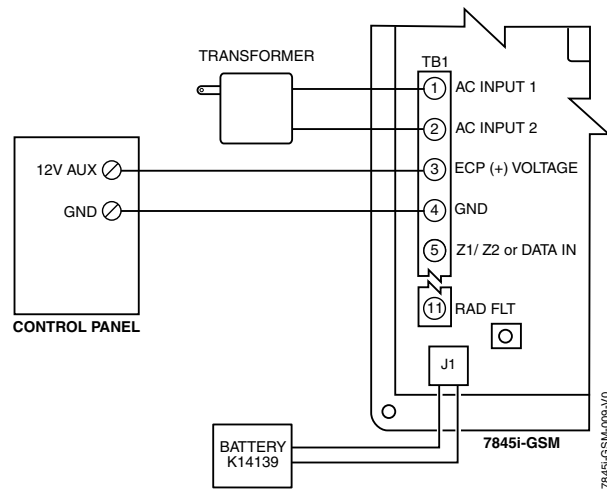

Figure 10. Powering the 7845i-GSM

NOTE: When calculating the total load on the auxiliary power output of the control panel, budget 10mA for the 7845i-GSM when using ECP mode.

Backup Battery Connection

The included battery (K14139) is used for backup in the event of a system power loss.

- The battery can provide over 24 hours of system life in the event of a power failure.
- A programmable power loss message can alert the AlarmNet Control Center when system power is lost (power loss messages are reported within 1-3 hours of actual loss).
- The module transmits a low-battery message (programmable) when the battery reaches $5.7V \pm 5\%$, indicating subsequent message may not be transmitted.
- The system shuts down when the battery voltage falls below 5.1V, and radio transmissions are no longer possible.
- If system power is restored before the module shuts down, a power-on restore message is sent within 1-3 hours after power is restored, and the battery is recharged using the 7845i-GSM's built-in battery charger. If system power is restored after the 7845i-GSM has shut down, a power-on reset condition exists, the module initializes itself and the battery will recharge.

Install the battery as follows, and refer to the *Summary of Connections* diagram at the end of this document.

1. Place the battery inside the case back.
2. Snap the right side of the battery clip onto the inside of the case back and secure the left side with the screw provided.



1. Do not plug the battery in until after you have powered-up the 7845GSM.
2. If using a LynxR-I, do not connect the module's backup battery. The LynxR-I backup battery will supply backup power in the event of a power outage.

Initial Power-Up Sequence

Before connecting power, check that the following have been completed:

- If using ECP, 4204 or 2-4204 Mode, terminal block TB1 V+ and GND terminals are connected to the control panel's auxiliary power output: 12VDC nominal.
- Plug in the transformer (or other main power source).
- Connect the red and black battery cables to the battery terminals. Connect battery cable to connector J1.
- Power up the control panel.
- Initially, all 7845GSM programming options are set to the factory default settings.

Programming the 7845i-GSM

In This Section

- ◆ General Information
- ◆ ECP Mode Programming
- ◆ Alternative Modes (Zone Trigger, 4204 and Two-4204)
- ◆ Alternative Mode Programming
- ◆ Exiting Programming Mode

General Information

The 7845i-GSM is designed to deliver alarms via the Internet to an AlarmNet central station or via the AlarmNet-G network, using GSM (Global System for Mobile) technology when the Internet is not available.

The 7845i-GSM uses 256 bit AES (Rijndael) encryption which is required for certain government installations.



The 7845i-GSM module requires an AlarmNet-I account. For new installations, please obtain the account information from the central station prior to programming this module. For replacement installations, the AlarmNet-i account is created automatically when the module is registered (based on the existing "C Series" account).

You can program a 7845i-GSM by one of the following methods:

- Through the AlarmNet Direct website
- Through use of a 7720P Programming Tool
- Through a programming mode in the control panel, on panels that support this option (e.g., VISTA-128BP and FBP)

Using the AlarmNet Direct website

To program the module via the website (if you are already signed up for this service), go to: <https://services.alarmnet.com/AlarmNetDirect/userlogin.aspx>

If you are not signed up for this service, click on "Dealer Sign-Up."

Log in and follow the on-screen prompts.

Please have the following information available when programming the module:

1. Primary City ID (two-digit number)
2. Primary Central Station ID (two-digit hexadecimal number)
3. Primary Subscriber ID (four-digit number)
4. MAC ID and MAC CRC number (located on the outside of box and on label inside module) or MIN number of the device you are replacing
5. Mode of operation of existing module if replacing a "C" series radio.

After programming is complete, you must transfer the data to the module and the module must be registered. Refer to *Section 4: Registration*, for further instructions.

Using a 7720P Programming Tool

Connect the 7720P Programming Tool; refer to Figure 9 in *Section 2*. The 7845i-GSM powers the 7720P Programming Tool via the programming jack, and automatically senses the presence of the 7720P when it is plugged in.

Each key of the 7720P has two possible functions: a normal function and a Shift function.

To perform a normal key function, simply press the desired key.

To perform a Shift function, press the [shift] key, and then press the appropriate key.

The prompts in this document reflect use of the 7720P Programming Tool. Table 2 below lists each normal and shift key function.

Table 2. 7720P Normal and Shift Key (shift LED lit) Functions

KEY	NORMAL KEY FUNCTION	SHIFT KEY FUNCTION
BS/ESC	[BS]: Press to delete entry	[ESC]: Press to quit program mode; also can reset programming defaults*
↓/↑	[↓]: Scroll down programming	[↑]: Scroll up programming
N/Y	[N]: Press for "NO" answer	[Y]: Press SHIFT-Y for "YES" answer
SHIFT	Press before pressing a SHIFT key function. Will light SHIFT LED. LED goes out once a key is pressed. Press again for each SHIFT function desired.	
1/A	[1]: For entering the number 1	[A]: For entering letter A
2/B	[2]: For entering the number 2	[B]: For entering letter B
3/C	[3]: For entering the number 3	[C]: For entering letter C
4/D	[4]: For entering the number 4	[D]: For entering letter D
5/E	[5]: For entering the number 5	[E]: For entering letter E
6/F	[6]: For entering the number 6	[F]: For entering letter F
7/S	[7]: For entering the number 7	[S]: For entering letter S
8/T	[8]: For entering the number 8	[T]: For entering letter T
9/X	[9]: For entering the number 9	[X]: For entering letter X
SPACE	[SPACE]: For scrolling option list	No SHIFT function
0	[0]: For entering the number 0	No SHIFT function
#/ENTER	[#/ENTER]: Starts programming mode; Press to accept entries	No SHIFT function

* Active only when the "Exit Programming Mode" prompt is displayed.

Using the Control Panel Programming Mode

Some control panels support programming of the 7845i-GSM through the control panel programming mode (e.g., VISTA-128BP). If programming through the control panel, only the ECP Mode programming options are available. The "mode" questions will not be displayed, and the mode cannot be changed. For a description of key functions on the control panel keypad, and how they map to the 7720P Programming tool, refer to the control panel's Programming Guide.

Programming Conventions

Programming is accomplished by answering a series of prompts (questions). Most prompts require only a [Y]es or [N]o response, while others require a numerical response (ID numbers, etc.).

The current value is displayed on the second line in parentheses (). A "?" indicates an invalid entry.

Use the [ENTER] key to accept the current entry and proceed to the next prompt. If the entered value is invalid, pressing [ENTER] re-displays the prompt; the next prompt is not displayed until a valid answer is entered.

Use the up/down arrow keys to scroll through the programming questions without changing any values. Press the [ESC] key to go to the end of the list of questions.

ECP Mode Programming

The 7845i-GSM supports ECP messaging to communicate with the control panel. LRR-enabled control panels send Contact ID format alarms to the 7845i-GSM directly on the 4-wire console bus. Not all control panels support the LRR interface on ECP, so be sure to check the Installation and Setup Guide of the control panel to see if it supports this feature.

Press the [ENTER] key to begin programming.

NOTE: The central station can remotely block access to local device programming. If this has been done, the following prompt appears:

Access to Prog Mode Denied

NOTE: The default programming values for ECP mode are listed in each prompt below.

Table 3: Programming a 7845i-GSM for ECP mode only.

	PROMPTS	ENTRY	OPTIONS	DESCRIPTION	
1	Strt Prog Mode? (Y/N)_		[Y], [N]	Enters programming mode.	
2	Enter Password:		[0-9, A-F, N, S, T, X, Y]	If a password has been previously assigned, this prompt appears. Enter a 4-digit password (0-9, A-F, N, S, T, X, Y). The next prompt appears.	
3	Program Device? (Y/N)_		[Y], [N]	To begin programming the module, press [Y] and go to Prompt 9: "Device Mode." To create a password if none has been assigned, press [N] and go to Prompt 4: "Create Password." To change an existing password, press [N] and go to Prompt 5: "Change Password."	
4	Create Password? (Y/N)_		[Y], [N]	Passwords can be used to protect account and programming information. If no password has been assigned, this prompt appears after pressing [N] at the "Program Device?" prompt. If a password is desired, press [Y] and go to "Enter Password."	
5	Change Password? (Y/N)_		[Y], [N]	If a password has already been assigned, this prompt appears after pressing [N] at the "Program Device?" prompt. Press [Y] if you want to change the password. NOTE: To clear an existing password, without entering a new one, answer [Y] to the "Change Password?" prompt, then press the [Enter] key when prompted for the new password and its confirmation.	
6	Enter Password		[0-9, A-F, N, S, T, X, Y]	This prompt is displayed if [Y] was pressed in Prompt 4 or 5. Enter a 4-digit password (0-9, A-F, N, S, T, X, Y).	
7	Verify Password		[0-9, A-F, N, S, T, X, Y]	Re-enter the password as confirmation. If the password doesn't match the first entry, the following is displayed followed by the "Exit Prog. Mode?" prompt: <table border="1" style="margin-left: 20px;"> <tr> <td style="text-align: center;">Verify Not OK PSWD not created</td> </tr> </table> Otherwise, the "Exit Prog. Mode?" prompt is displayed directly.	Verify Not OK PSWD not created
Verify Not OK PSWD not created					
8	Exit Prog. Mode? (Y/N)_		[Y], [N] [ESC]	Exits program mode. Press [N] to go back to Prompt 3. Press [ESC] to load factory defaults. Refer to the <i>Exiting Programming Mode</i> paragraph in this section.	
9	Device Mode (ECP)_		<ul style="list-style-type: none"> • ECP • Zone Triggers • 4204 Emu • Two 4204s 	Press the [space] key to scroll through the modes of operation. Press [ENTER] to select ECP mode. See <i>Table 5</i> if programming other modes.	

Important Information Regarding Multi-Mode Options

Users can receive email notification of system events by using the Multi-Mode feature. In ECP mode, this is accomplished through emulation of a 4204 relay module, or two 4204 relay modules. When “4204-sourced” is selected, the user can be notified of up to four events, plus two additional events if using the optional communication device zones of 6 and 7. When “2-4204-sourced” is selected, the user can be notified of up to eight system events. The Multi-Mode address must match the address of a relay module enabled in the control panel (although you don’t actually connect a module). If using “2-4204-sourced,” the address of the second module is automatically assigned the next device address after the first 4204. Make sure that address is also enabled in the control panel. Program outputs to trigger on system events the user would like to be notified of through Output Device (Relay) programming in the control panel.

For LynxR-I/ReadyGuardR-I series controls (when available), if "4204 Sourced" is selected, you must enable Multi-Mode Address 6 or 7 in the control panel (program field *86). If "2-4204" Sourced is selected, you must enable both. These events are configured at the AlarmNet Total Connect website at: <https://services.alarmpnet.com/TotalConnect>

 Multi-Mode (email notification) is intended as a convenience for the user, and does not replace Central Station reporting of critical events (alarms, troubles, etc.).

UL Multi-Mode has not been evaluated by UL.

	PROMPTS	ENTRY	OPTIONS	DESCRIPTION
10	Multi Mode (Disabled)_		<ul style="list-style-type: none"> • Disabled • 4204 Sourced • 2-4204 Sourced 	Enable if you want system events sent by email to the user. Select "4204 Sourced" to send up to four events (plus two additional reports triggered by optional hardwire zones 6 and 7), or "2-4204 Sourced" to send eight events. Disable for normal alarm processing and go to Prompt 12: "Primary City ID".
11	Multi Mode Addr (12)_		[01-30]	This address must be programmed if using the Multi-Mode (email notification) feature. The device address must be unique from the normal LRR Device Address (Prompt 19) and the Keypad Address used for Remote Access or Direct Wire downloading. The address used must also be enabled as a 4204 relay module in Vista and First Alert control panels. See Important Information above.

Important Information Regarding Primary and Secondary Accounts (Questions 12-18)

Account information is provided by the central station administrator. If the control supports secondary account reporting, you will need secondary account information. The City ID, CS ID or Subscriber ID of the secondary account must differ from that of the primary account.

12	Primary City ID (??)_		[01-99]	Enter the 2-digit primary city ID, 01-99 (decimal).
13	Primary CS ID (??)		[01-FE]	Enter the 2-digit primary central station ID number, 01-FE (HEX).
14	Primary Sub ID (????)		[0001-9999]	Enter the 4-digit subscriber account number, 0001-9999 (decimal).
15	En. 2 nd CS Y/N (N)_		[Y], [N]	Applicable only if control supports Central Station #1 and #2 Category Enable reporting for the LRR device (e.g., VISTA-128BP, FA1660C, etc.). Used if reporting to a second central station is desired. If [N], go to Prompt 19: "Device Address."
16	2 nd City ID (??)_		[01-99]	Enter the 2-digit secondary city ID, 01-99 (decimal).
17	2 nd CS ID (??)_		[01-FE]	Enter the 2-digit second central station's ID number, 01-FE (HEX).

	PROMPTS	ENTRY	OPTIONS	DESCRIPTION
18	2 nd Sub ID (????)_		[0001-9999]	Enter the 4-digit subscriber account number for the second central station, 0001-9999.
19	Device Address (03)_		[01-30]	In ECP mode, the 7845i-GSM communicates with the panel as a Long Range Radio (LRR) device. Enter the appropriate ECP device address. For VISTA-10 and VISTA-20 series control panels, use address 03. For other controls, see the control panel's Installation and Setup Guide. NOTES: 1. When programming the control, enable the LRR output. 2. The device address must be unique from the "Keypad Address" entered in Prompt 22, and the Multi-Mode Address entered in Prompt 11.
20	RemoteAccess Y/N (N)_		[Y], [N]	Press [Y] to allow the end user to access their system via a website. Availability of this service is controlled by the dealer via the web-based programming tool on the AlarmNet Direct website.
21	Direct Wire Y/N (N)_		[Y], [N]	Applies only to VISTA-128BP/250BP and FBP Series controls, and FA1660C and 1700C Series controls. Enables Direct Wire Downloading over IP. If [N], and if Prompt 20: "Remote Access" is disabled, skip to Prompt 23: "Supervision."
22	Keypad Address (28)_		[01-30]	This address must be programmed if using either the Remote Access feature of Direct Wire downloading. Enter the appropriate device address. NOTES: 1. This address must also be programmed as an alpha keypad in the control panel or an AUI (advanced user interface) type device, if a full enhanced graphic interface to the system is desired and the control panel supports it. DO NOT connect an actual keypad (or any other device) assigned to this address. 2. If using a compatible LynxR-I series control (when available), this address must be set to "1." 3. This address must be unique from the "Device Address" entered in Prompt 19.
23	Supervision (24 Hours)_		<ul style="list-style-type: none"> • 30 Day • 24 Hrs • None 	The AlarmNet network must hear at least one supervisory message from the module during this supervision period; otherwise, AlarmNet notifies the central station that a communication failure has occurred. (If the supervision period is changed after registration, you must re-register the module.) Press the [space] key to scroll through choices. UL NOTE: Must be set to 24 hours.
24	GSM Rollover Y/N (Y)_		[Y], [N]	If enabled, all messages (including AlarmNet network supervisory messages) are sent over the GSM network in the event of an Internet failure. If disabled, all messages (except AlarmNet network supervisory messages) are sent automatically over the GSM network in the event of an Internet failure.
25	GSM 24Hr Tst Y/N (N)_		[Y], [N]	If enabled, the 7845i-GSM sends a message once a day to verify module operation. A "secondary communication path loss" message is generated if the message is not successfully delivered. UL NOTE: Must be set to "Y".

	PROMPTS	ENTRY	OPTIONS	DESCRIPTION
26	Old Alarm Time 10 Minutes_		<ul style="list-style-type: none"> •10 Minutes • 15 Minutes • 30 Minutes • 1 Hour • 2 Hours • 4 Hours • 8 Hours • 12 Hours • 24 Hours 	<p>Sets how long an undeliverable alarm is retried for delivery to the central station. If the message is not validated, it is retried until the old alarm time is reached or the message is validated.</p> <p>Press the [space] key to scroll through choices.</p> <p>UL NOTE: Must be 10 minutes.</p>
27	IP Fit Time (60 mins)_		[01-99]	<p>In the event there is a loss of contact with the network over the Ethernet connection, enter the time delay (in minutes) before the 7845i-GSM notifies the central station. IP failure will always be sent to the central station as Primary Communication Path Failure.</p> <p>UL NOTE: Must be one (01) minute.</p>
28	GSM Fit Time (60 mins)_		[01-99]	<p>In the event the module detects a communication path failure, enter the time delay (in minutes) before the 7845i-GSM notifies the central station. A GSM failure will always be sent to the central station as Secondary Communication Path Failure.</p> <p>UL NOTE: Must be one (01) minute.</p>
29	Notify Panel Of_ (Neither Fault)		<p>[Neither fault]</p> <p>[Both IP and GSM Faults]</p>	<p>If "Both IP and GSM Fault" is selected, the device will only notify the control panel if both communication paths fail, but will always send notification of either failure to the central station.</p> <p>NOTE: The fault relay output (if programmed) will be triggered only if "Both IP and GSM Faults" is selected. Press the [space] key to scroll through choices.</p> <p>UL NOTE: Must be set to "Both IP and GSM Faults".</p>
30	Fit Rel ON Y/N (N)_		[Y], [N]	<p>If enabled, the fault open collector output is normally energized to ground, and de-energizes (open circuit) in the event of a module fault. For conditions that trip the fault relay refer to <i>Module Supervision Features</i> in Section 1.</p> <p>Set to [Y] if fail-safe mode is desired.</p> <p>See <i>Wiring for Module Fault Relay</i> in Section 2.</p> <p>UL NOTE: Must be set to "Y."</p>
31	Pwr Loss Rpt Y/N (Y)_		[Y], [N]	<p>Sends a primary power loss report to the central station within 1-3 hours after its detection. A restore report is sent within 1-3 hours after power is restored.</p> <p>UL NOTE: Must be set to "Y."</p>
32	Low Bat Rpt Y/N (Y)_		[Y], [N]	<p>Sends a low-battery report when a low battery condition exists. A low battery restore is automatically sent when the low battery condition clears.</p> <p>UL NOTE: Must be set to "Y" unless used with LynxR-I series controls. Must be set to "N" when using LynxR-I series controls.</p>
33	Tamper Rpt Y/N (Y)_		[Y], [N]	<p>Sends a tamper report when the module detects a tamper condition. A tamper restore is automatically sent when the tamper condition clears.</p> <p>UL NOTE: Must be set to "Y."</p>

Important Information Regarding Zone Input Options

ECP mode supports two optional hardwire zone input triggers by making connections to the module's zone 6 and/or zone 7 terminals and programming the appropriate zone trigger options below.

Each zone input can be programmed to cause an alarm under one of the following conditions:

- (V+), where a positive voltage causes an alarm for normally low connections (voltage trigger, NO, NC)
- (V-), where a ground trigger causes an alarm for normally high connections (open collector, NO, NC)
- (EOLR) End of Line Resistor, where the input is supervised by a 2K EOL resistor. The zone can be triggered by open collector, voltage trigger, NO, NC.

In addition to the above, zones can be programmed for an Inverted Trigger, where the alarm and normal states of the zones are inverted; this can serve a fail-safe supervisory purpose for certain installations.

These zone inputs can also be programmed for restore reporting, and for delayed reporting, which allows time for the user to abort false alarms.

NOTE: Optional hardwire zones report in ADEMCO High-Speed format.

	PROMPTS	ENTRY	OPTIONS	DESCRIPTION
34	Enable Zn6 Y/N (N)_		[Y], [N]	Enables alarm reporting for zone 6. If [N], skip to Prompt 39: "Enable Zn7."
35	Zn6 Trigger Type (V+)_		<ul style="list-style-type: none"> • (V+) • (V-) • (EOLR) 	Selects the triggering method for this zone input. Press the [space] key to scroll through choices.
36	Invert Zn6 Y/N (N)_		[Y], [N]	Inverts the alarm and normal states of the zone 6 trigger; otherwise uses normal input signal.
37	Restore Zn6 Y/N (Y)_		[Y], [N]	Enables restore reporting for zone 6.
38	Delay Zn6 (secs) (00)_		[01-15] [00] = no delay	Defines the reporting delay in seconds for zone 6.
39	Enable Zn7 Y/N (N)_		[Y], [N]	Enables alarm reporting for zone 7. If [N], skip to Prompt 44: "Use DHCP."
40	Zn7 Trigger Type (V)_		<ul style="list-style-type: none"> • (V+) • (V-) • (EOLR) 	Selects the triggering method for this zone input. Press the [space] key to scroll choices.
41	Invert Zn7 Y/N (N)_		[Y], [N]	Inverts the alarm and normal states of the zone 7 trigger; otherwise, uses normal input signal.
42	Restore Zn7 Y/N (Y)_		[Y], [N]	Enables restore reporting for zone 7.
43	Delay Zn7 (secs) (00)_		[01-15] [00] = no delay	Defines the reporting delay in seconds for zone 7.
44	Use DHCP Y/N (Y)_		[Y], [N]	Dynamically allocates the IP addresses (recommended); then skip to Prompt 49: "Enable Pwr Save". If [N], uses fixed IP addresses.
45	NIC IP Address: 255.255.255.255_		12 digit: xxx.xxx.xxx.xxx	Enter the 4-part address for this device. The 4 parts of the address must be separated by spaces (displayed as periods in Review mode).
46	Subnet Mask: 255.255.255.255_		12 digit: xxx.xxx.xxx.xxx	Enter the 32-bit address mask used to indicate the portion (bits) of the IP address that is being used for the subnet address. The 4 parts of the address must be separated by spaces (displayed as periods in Review mode).
47	Gateway IP Addr: 255.255.255.255_		12 digit: xxx.xxx.xxx.xxx [0.0.0.0.] = not used	Enter the 4-part address assigned to the Gateway. The 4 parts of the address must be separated by spaces (displayed as periods in Review mode).

	PROMPTS	ENTRY	OPTIONS	DESCRIPTION
48	DNS Serv IP Addr: 255.255.255.255_		12 digit: xxx.xxx.xxx.xxx [0.0.0.0.] = not used	Enter the 4-part IP address assigned to the DNS (Domain Name System) server. The 4 parts of the address must be separated by spaces (displayed as periods in Review mode).
49	Enable Pwr Save (Y)_		[Y], [N]	For 24 hour UL Battery Backup requirement, this feature must be enabled, or the unit must be powered by an appropriate UL listed UPS. If connectivity problems occur with certain routers or switches disable this option.
50	Review? Y/N		[Y] = review [N] = exit	Reviewing Programming Mode Entries To review the programming options (to ensure that the correct entries have been made), press [Y]. The programming prompts are displayed again. Use the up/down arrow keys to scroll through the program fields without changing any of the values. If a value requires change, simply type in the correct value. When the last field is displayed, the "REVIEW?" prompt again appears. To exit the programming mode , press [N] in response to the "REVIEW?" prompt, and refer to <i>Exiting Programming Mode</i> at the end of this section.

ECP Status Codes

When the 7845i-GSM is configured for ECP mode, it sends status messages to the control panels for battery, power, tamper, and network connectivity failures. Some of the control panels (e.g., VISTA-10P, VISTA-15P and VISTA-20P Series) display these on the keypad as "LngRng Radio" followed by a 4-digit code (listed in Table 4). In addition, the Contact ID codes (listed in Appendix A) for these conditions are sent to the central station by the module.

Table 4. Common ECP Keypad Display Status Codes

STATUS CODE	DESCRIPTION
0000	Control panel lost communication with 7845i-GSM.
0880	7845i-GSM tamper detected (cover removed).
4005	7845i-GSM has lost contact with AlarmNet.
000F	7845i-GSM is not registered; account not activated.
0019	7845i-GSM shutdown.
0400	7845i-GSM power-on reset AND the control panel lost communications with 7845i-GSM.
0C80	7845i-GSM power on reset AND tamper detected.
0C8F	7845i-GSM power on reset AND tamper detected AND not registered.
08E0	7845i-GSM tamper detected and 7845i-GSM battery low.
3000	Primary power loss (will only be displayed in conjunction with another event).
8000	Battery charger failure (will only be displayed in conjunction with another event).
0060	Low battery (will only be displayed in conjunction with another event).

Alternative Modes (Zone Trigger, 4204 and Two-4204)

Zone Trigger Mode

There are six input zones available on the 7845i-GSM. Each zone is selectable for +V, -V, or EOLR trigger. The first zone input can detect both pulsed and steady signals if connected to a bell output. Additionally, the first zone input can be programmed to detect a single pulse (characteristic of a Panic indication on the Lynx, LynxR or LynxR-EN control panel by enabling the Lynx Panic option). If the programming option "Lynx Panic" is enabled, the

7845i-GSM reports an alarm on zone 3. No restores are reported for this zone. If this option is selected, the second physical zone input is ignored.

When using Zone Trigger mode, messages are sent in ADEMCO High-Speed format.

Zones 3, 4, 5, 6 and 7 are voltage trigger inputs located on TB1 pins 6-10. If the Lynx Panic feature is being used, do not connect zone 3 (the second physical zone input).

Refer to Table 5 for Zone Trigger Mode programming and follow the prompts that pertain to Zone Trigger Mode. A check mark (✓) indicates whether the prompt applies to that mode.

4204 Emulation Mode

In 4204 Emulation Mode, the 7845i-GSM communicates with a compatible Honeywell VISTA series or First Alert control panel as though it were a 4204 Relay Module. If two 4204s are enabled in the module, it acts as two 4204s at consecutive device addresses. The control panel must be configured to recognize one or two 4204 relay modules accordingly. On VISTA-32FB (or higher) control panels and First Alert equivalents, addresses 6 and 13 should not be used when the secondary 4204 is enabled. Messages are sent in ADEMCO High-Speed format.

NOTE: See your control panel Installation and Setup Guide for the number of 4204 modules supported. The LynxR-I does not support 4204 mode.

4204 Emulation Mode Options

For control panels that do not support LRR-ECP communication, the 4204 Emulation modes provide a means of sending up to eight unique reports based on defined system conditions. In 4204 mode, the 7845i-GSM functions as a logical 4204 Relay Module, where each relay number, referred to in the module as zone number, can be programmed to send a report based on the output function programmed in the control for that relay. Each relay-zone can also be programmed to send a restore message of the reported condition, can be set to delay transmission of messages, and can be programmed to send reports only when a conditional zone is triggered (armed), (see *Important Information Regarding Zone Input Options* later in this section).

In single 4204 mode, the 7845i-GSM supports up to four relay-zones. In Two-4204 mode, the 7845i-GSM functions as two 4204 modules, supporting up to eight relay-zones.

4204 Relay Outputs map to 7845i-GSM zones as follows:

First 4204 Zones (device address entered in Prompt 14):	Second 4204 Zones (device address entered in Prompt 14, plus 1):
Relay 1 = Zone 1	Relay 1 = Zone 5
Relay 2 = Zone 2	Relay 2 = Zone 6
Relay 3 = Zone 3	Relay 3 = Zone 7
Relay 4 = Zone 4 or conditional zone trigger if “report only if armed” is selected in any zone 1-3 when using single 4204 mode.	Relay 4 = Zone 8 or conditional zone trigger if “report only if armed” is selected in any zone 1-7 when using Two-4204 mode.
NOTE: Zone 4 status is not reported when being used as the conditional (armed) trigger zone.	NOTE: Zone 8 status is not reported when being used as the conditional (armed) trigger zone or if tamper reporting is enabled.

When using the 7845i-GSM in 4204 Emulation Mode, DO NOT enable the Long-Range Radio module in control panel programming. Instead, enable 4204 relay module address(es) and program the appropriate relay activation functions for the relay-zones being used. In some control panels, it is called “relay programming” and in others it is called “output device programming.” It is recommended that “close and stay closed” (usually choice 2) action is selected. Selection of momentary activation will cause the 7845i-GSM to generate an alarm and NOT a restore, even if the 7845i-GSM is programmed to send a restore for the given zone.

In 4204 mode, messages are reported in ADEMCO High-Speed format. Zone alarms (status 7) are reported with “1” (alarm) or “3” (restore) displayed in the zone position for the respective zone (e.g. alarm on zone 2: 5155 5555 7; restore 5355 5555 7). A supervision fault trouble message is automatically sent if the module detects no activity on its connection to the control. The message is: 5555 5515 5; restore message is: 5555 5535 5.

Refer to Table 5 for 4204 Emulation Mode programming and follow the prompts that pertain to 4204 or Two-4204 mode. A check mark (✓) indicates whether the prompt applies to that mode.

Alternative Mode Programming

Press the [ENTER] key to begin programming and follow the prompts for the mode of operation being programmed.

NOTE: The central station can remotely block access to local device programming. If this has been done, the following prompt appears:

Access to Prog Mode Denied

Table 5: Programming a 7845i-GSM for Zone Trigger, 4204 Emulation, or Two-4204 Emulation modes.

	PROMPTS	ZONE TRIG.	4204/2-4204	ENTRY	OPTIONS	DESCRIPTION	
1	Strt Prog Mode? Y/N_	✓	✓		[Y], [N]	Enters programming mode.	
2	Enter Password	✓	✓		[0-9, A-F, N, S, T, X, Y]	If a password has been previously assigned, this prompt appears. Enter a 4-digit password (0-9, A-F, N, S, T, X, Y). The next prompt appears.	
3	Program Device? Y/N_	✓	✓		[Y], [N]	To begin programming the module, press [Y] and go to Prompt 9: "Device Mode." To create a password if none has been assigned, press [N] and go to Prompt 4: Create Password. To change an existing password, press [N] and go to Prompt 5: "Change Password."	
4	Create Password? Y/N_	✓	✓		[Y], [N]	Passwords can be used to protect account and programming information. If no password has been assigned, this prompt appears after pressing [N] at the "Program Device?" prompt. If a password is desired, press [Y] and go to Prompt 6: "Enter Password."	
5	Change Password? Y/N_	✓	✓		[Y], [N]	If a password has already been assigned, this prompt appears after pressing [N] at the "Program 7845?" prompt. Press [Y] if you want to change the password. NOTE: To clear an existing password, without entering a new one, answer [Y] to the "Change Password?" prompt, then press the [Enter] key when prompted for the new password and its confirmation.	
6	Enter Password	✓	✓		[0-9, A-F, N, S, T, X, Y]	This prompt is displayed if [Y] was pressed in Prompt 4 or 5. Enter a 4-digit password (0-9, A-F, N, S, T, X, Y).	
7	Verify Password	✓	✓		[0-9, A-F, N, S, T, X, Y]	Re-enter the password as confirmation. If the password doesn't match the first entry, the following is displayed followed by the "Exit Prog. Mode?" prompt: <table border="1" style="margin: 5px auto;"><tr><td style="text-align: center;">Verify Not OK PSWD not created</td></tr></table> Otherwise, the "Exit Prog. Mode?" prompt is displayed directly.	Verify Not OK PSWD not created
Verify Not OK PSWD not created							

	PROMPTS	ZONE TRIG.	4204/2-4204	ENTRY	OPTIONS	DESCRIPTION
8	Exit Prog. Mode? Y/N_	✓	✓		[Y], [N] [ESC]	Exits program mode. Press [N] to go back to Prompt 3. Press [ESC] to load factory defaults. Refer to the <i>Exiting Programming Mode</i> paragraph in this section.
9	Device Mode (ECP)_	✓	✓		• ECP • Zone Trig. • 4204 Emu • Two 4204s	Press the [space] key to scroll through the modes of operation. Press [ENTER] to select mode. See <i>Table 3</i> for ECP mode programming.

Important Information Regarding Multi-Mode

In Zone Trigger mode, the options for Multi-Mode are "Enabled" or "Disabled." If enabled, whenever a zone on the communication device is triggered, a corresponding email message is sent INSTEAD of normal central station reports. Cover tamper will send email event 8. All communication device system events (such as power loss, low battery, etc.) are still sent to AlarmNet.

Events used to send email messages are defined on the Honeywell Total Connect web site, and must correspond to events triggering the hardwired zones.



Multi-Mode (email notification) is intended as a convenience for the user, and does not replace Central Station reporting of critical events (alarms, troubles, etc.).

UL

Multi-Mode has not been evaluated by UL.

10	Multi Mode (Disabled)_	✓			• Enabled • Disabled	Enable if you want system events sent by email to the user. Disable for normal alarm processing.
----	---------------------------	---	--	--	-------------------------	---

Important Information Regarding Primary Account (Questions 11-13)

Account information is provided by the central station administrator.

11	Primary City ID (??)_	✓	✓		[01-99]	Enter the 2-digit primary city ID, 01-99 (decimal).
12	Primary CS ID (???)	✓	✓		[01-FE]	Enter the 2-digit primary central station ID number, 01-FE (HEX).
13	Primary Sub ID (????)	✓	✓		[0001-9999]	Enter the 4-digit subscriber account number, 0001-9999 (decimal).
14	Device Address (12)_		✓		[01-15]	The 7845i-GSM communicates with the control panel as a 4204 relay module. Enter the appropriate address. For VISTA-10P, and FA130CP Series control panels, this must be address 12. For other controls, see the control panel's Installation and Setup Guide. NOTES: 1. The 4204 protocol limits address range to 01-15. If using 2-4204 mode, the 7845i-GSM assigns the second 4204 to the next higher device address (e.g., if entering address 12 for the first 4204, then address 13 is automatically assigned to the second 4204 module). Program the control panel accordingly. 2. The device address(es) must be unique from the "Keypad Address" entered in Prompt 17 and any other address used on the control panel.
15	RemoteAccessY/N (N)_		✓		[Y], [N]	Press [Y] to allow the end user to access their system via a website. Availability of this service is controlled by the dealer via the web-based programming tool on the AlarmNet Direct website.

	PROMPTS	ZONE TRIG.	4204/2-4204	ENTRY	OPTIONS	DESCRIPTION
16	Direct Wire Y/N (N)_		✓		[Y], [N]	Applies only to VISTA-128BP/250BP and FBP Series controls, and FA1660C and 1700C Series controls. Enables Direct Wire Downloading over IP. If [N], and if Prompt 15: "Remote Access" is disabled, skip to Prompt 18: "Supervision."
17	Keypad Address (28)_		✓		[01-30]	This address must be programmed if using either the Remote Access feature or Direct Wire downloading. Enter the appropriate device address. NOTES: 1. This address must also be programmed as an alpha keypad in the control panel or an AUI (Advanced User Interface) type device, if a full enhanced graphic interface to the system is desired and the control panel supports it. DO NOT connect an actual keypad (or any other device) assigned to this address. 2. If using a compatible LynxR-I series control (when available), this address must be set to "1." 3. This address must be unique from the "Device Address" entered in Prompt 14, and cannot equal that device address plus 1 (one) if using 2-4204 mode.
18	Supervision (24 Hours)_	✓	✓		<ul style="list-style-type: none"> • 30 Day • 24 Hrs • None 	The AlarmNet network must hear at least one supervisory message from the module during this supervision period; otherwise, AlarmNet notifies the central station that a communication failure has occurred. (If the supervision period is changed after registration, you must re-register the module.) Press the [space] key to scroll through choices. UL NOTE: Must be set to 24 hours.
19	GSM Rollover Y/N (Y)_	✓	✓		[Y], [N]	If enabled, all messages (including AlarmNet network supervisory messages) are sent over the GSM network in the event of an Internet failure. If disabled, all messages (except AlarmNet network supervisory messages) are sent automatically over the GSM network in the event of an Internet failure.
20	GSM 24Hr Tst Y/N (N)_	✓	✓		[Y], [N]	If enabled, the 7845i-GSM sends a message once a day to verify module operation. A "secondary communication path loss" message is generated if the message is not successfully delivered. UL NOTE: Must be set to "Y".
21	Old Alarm Time 10 Minutes_	✓	✓		<ul style="list-style-type: none"> • 10 Min • 15 Min • 30 Min • 1 Hr • 2 Hrs • 4 Hrs • 8 Hrs • 12 Hrs • 24 Hrs 	Sets how long an undeliverable alarm is retried for delivery to the central station. If the message is not validated, it is retried until the old alarm time is reached or the message is validated. Press the [space] key to scroll through choices. UL NOTE: Must be set to 10 minutes.

	PROMPTS	ZONE TRIG.	4204/2-4204	ENTRY	OPTIONS	DESCRIPTION
21	IP Fit Time (60 mins)_	✓	✓		[01-99]	In the event there is a loss of contact with the network over the Ethernet connection, enter the time delay (in minutes) before the 7845i-GSM notifies the central station. IP failure will always be sent to the central station as Primary Communication Path Failure. UL NOTE: Must be one (01) minute.
22	GSM Fit Time (60 mins)_	✓	✓		[01-99]	In the event the module detects a communication path failure, enter the time delay (in minutes) before the 7845i-GSM notifies the central station. A GSM failure will always be sent to the central station as Secondary Communication Path Failure. UL NOTE: Must be one (01) minute.
23	Notify Panel Of (Neither Fault)_	✓	✓		[Neither fault] [Both IP and GSM Faults]	If "Both IP and GSM Fault" is selected, the device will only notify the control panel if both communication paths fail, but will always send notification of either failure to the central station. NOTE: The fault relay output (if programmed) will be triggered only if "Both IP and GSM Faults" is selected. Press the [space] key to scroll through choices. UL NOTE: Must be set to "Both IP and GSM Faults".
24	Fit Rel ON Y/N (N)_	✓	✓		[Y], [N]	If enabled, the fault open collector output is normally energized to ground, and de-energizes (open circuit) in the event of a module fault. For conditions that trip the fault relay refer to <i>Module Supervision Features</i> in Section 1. Set to [Y] if fail-safe mode is desired. See <i>Wiring for Module Fault Relay</i> in Section 2. UL NOTE: Must be set to "Y".
25	Pwr Loss Rpt Y/N (Y)_	✓	✓		[Y], [N]	Sends a primary power loss report to the central station within 1-3 hours after its detection. A restore report is sent within 1-3 hours after power is restored. UL NOTE: Must be set to "Y".
26	Low Bat Rpt Y/N (Y)_	✓	✓		[Y], [N]	Sends a low-battery report when a low battery condition exists. A low-battery restore is automatically sent when the low battery condition clears. UL NOTE: Must be set to "Y" unless used with LynxR-I series controls. Must be set to "N" when using LynxR-I series controls.
27	Tamper Rpt Y/N (Y)_	✓	✓		[Y], [N]	Sends a tamper report when the module detects a tamper condition. A tamper restore is automatically sent when the tamper condition clears. UL NOTE: Must be set to "Y".
28	Lynx Panic Y/N (N)_	✓			[Y], [N]	Applies only if used with a Lynx, LynxR or LynxR-EN control LRR trigger connected to the module's zone terminal. Reports a Panic alarm on zone 3 when the module detects a single pulse on zone 1. No restores are generated for a Panic alarm.

Important Information Regarding Zone Input Options

If desired, **4204 mode** supports two optional hardwire zone input triggers by making connections to the module's zone 6 and/or zone 7 terminals and programming the appropriate zone trigger options below.

NOTE: These triggers are not available when using 2-4204 mode.

Zone Trigger Mode provides six hardwire zone input triggers by making connections to the module's zone terminals and programming the appropriate zone trigger options below. Zones are numbered 1-7, with zone 2 serving as a reporting zone only (see Bell Output Zone below).

Bell Output Zone 1 (and 2): The zone 1 terminal can detect both pulsed and steady signals. If connecting the bell output to the 7845i-GSM zone causes a bell fault on the control panel, enable the "Trip Inputs 1or2" option. The 7845i-GSM reports an alarm on zone 1 (fire) when it detects a pulsed signal and an alarm on zone 2 (burglary) when it detects a steady signal.

Telco Zone and Open/Close Zone: Dedicated zones can be assigned as the telco fault zone and/or an open/close (arm/disarm) reporting zone. When triggered, these zones report a telco line fault or open/close report respectively, in ADEMCO High-Speed format. Connect the appropriate trigger from the control to the selected zone input for each of these options.

Input Trigger Types: Triggering of each zone input can be programmed to cause an alarm under one of the following conditions:

- (V+), where a positive voltage causes an alarm for normally low connections (voltage trigger, NO, NC)
- (V-), where a ground trigger causes an alarm for normally high connections (open collector, NO, NC)
- (EOLR) End of Line Resistor, where the input is supervised by a 2K EOL resistor. The zone can be triggered by open collector, voltage trigger, NO, NC.

Inverted Trigger: Zones can be programmed for inverted trigger, where the alarm and normal states of the zones are inverted; this can serve a fail-safe supervisory purpose for certain installations.

Restore and Delayed Reports: Zone inputs can be programmed for restore reporting, and for delayed reporting (allowing time for the user to abort false alarms).

UL NOTE: Zone restoral must be enabled.

Report Only if Armed option: To help eliminate redundant reports, zone alarms can be restricted to report only if a conditional zone is triggered (armed). If this feature is desired, the conditional zone is automatically used as the "arming" zone. Connect the appropriate control panel trigger to the conditional (arming) zone. The trigger must be programmed as necessary in the control panel.

The conditional (arming) zone on the module is a different dedicated zone for each programming mode, as follows:

Mode	Conditional (Arming) Zone
Zone Trigger	7
4204	4
2-4204	8

IMPORTANT: If any zone (zones 1-6 in zone trigger mode, zones 1-3 in 4204 mode, zones 1-7 in 2-4204 mode) is set for Report Only if Armed, the conditional (arming) zone becomes unavailable for reporting (as it is reserved for the "arming" trigger connection).

29	Trip Inputs 1or2 w/Bell Out (N)_	✓			[Y], [N]	Use if the zone 1 connection to the control's bell output causes a bell fault on the control panel. NOTES: 1. If used, EOLR trigger type is not available for zones 1 and 3. 2. Do not use with Lynx controls.
----	---	---	--	--	----------	--

	PROMPTS	ZONE TRIG.	4204/ 2-4204	ENTRY	OPTIONS	DESCRIPTION
30	Telco Zone (0)_	✓	✓		Zone Trig: [3-7] 4204: [1-4] 2-4204: [1-8] [0] = not used	See Important Information Regarding Zone Input Options on previous page. Enter the zone number to be used for telco line fault reports. This zone assignment must be unique from the open/close zone selected in Prompt 31. Zone Trigger Mode: If any zone is programmed for "report only if armed," zone 7 cannot be used. If Lynx Panic is enabled, zone 3 cannot be used. 4204 Mode: If any zone is programmed for "report only if armed," zone 4 cannot be used. 2-4204 Mode: If any zone is programmed for "report only if armed," or if tamper is enabled, zone 8 cannot be used. NOTE: Connect the telco line fault output (or relay output programmed for "telco line fault") to the telco zone.
31	Open/Close Zone (0)_	✓	✓		Zone Trig: [3-7] 4204: [1-4] 2-4204: [1-8] [0] = not used	Enter the zone number to be used for open/close (arm/disarm) reports. This zone assignment must be unique from the telco zone selected in Prompt 30. Zone Trigger Mode: If any zone is programmed for "report only if armed," zone 7 cannot be used as an open/close zone. If Lynx Panic is enabled, zone 3 cannot be used. 4204 Mode: If any zone is programmed for "report only if armed," zone 4 cannot be used as an open/close zone. 2-4204 Mode: If any zone is programmed for "report only if armed," or if tamper is enabled, zone 8 cannot be used as an open/close zone. NOTE: Connect an open/close (arm/disarm) trigger (or relay output) from the control panel to the open/close zone.
32	Zn1 Trigger Type (V+)_	✓			• (EOLR) • (V+) • (V-)	Selects the triggering method for this zone input. Press the [space] key to scroll through choices.
33	Restore Zn1 Y/N (Y)_	✓	✓		[Y], [N]	Enables restore reporting for zone 1.
34	Delay Zn1 (secs) (00)_	✓	✓		[01-15] [00] = no delay	Defines the reporting delay in seconds for zone 1.
35	Rpt Zn1 ONLY if Armed (N)_	✓	✓		[Y], [N]	Report alarms on zone 1 ONLY if the conditional zone (zone 7 in zone trigger mode; zone 4 in 4204 mode; or zone 8 in 2-4204 mode) is triggered (armed). If [N], always reports alarms on zone 1.
36	Invert Zn2 Y/N (N)_	✓			[Y], [N]	Inverts the alarm and normal states of the zone 2 trigger; otherwise uses normal input signal.
37	Restore Zn2 Y/N (Y)_	✓	✓		[Y], [N]	Enables restore reporting for zone 2.
38	Delay Zn2 (secs) (00)_	✓	✓		[01-15] [00] = no delay	Defines the reporting delay in seconds for zone 2.

	PROMPTS	ZONE TRIG.	4204/ 2-4204	ENTRY	OPTIONS	DESCRIPTION
39	Rpt Zn2 ONLY if Armed (N)_	✓	✓		[Y], [N]	Reports alarms on zone 2 ONLY if the conditional zone (zone 7 in zone trigger mode; zone 4 in 4204 mode; zone 8 in 2-4204 mode) is triggered (armed). If [N], always reports alarms on zone 2.

If Lynx Panic is enabled, then skip to Prompt 44: "Rpt Zn3 ONLY if Armed."

40	Zn3 Trigger Type (V+)_	✓			<ul style="list-style-type: none"> • (EOLR) • (V+) • (V-) 	Selects the triggering method for this zone input. Press the [space] key to scroll through choices.
41	Invert Zn3 Y/N (N)_	✓			[Y], [N]	Inverts the alarm and normal states of the zone 3 trigger; otherwise uses normal input signal.
42	Restore Zn3 Y/N (Y)_	✓	✓		[Y], [N]	Enables restore reporting for zone 3.
43	Delay Zn3 (secs) (00)	✓	✓		[01-15] [00] = no delay	Defines the reporting delay in seconds for zone 3.
44	Rpt Zn3 ONLY if Armed (N)_	✓	✓		[Y], [N]	Reports alarms on zone 3 ONLY if the conditional zone (zone 7 in zone trigger mode; zone 4 in 4204 mode; zone 8 in 2-4204 mode) is triggered (armed). If [N], always reports alarms on zone 3. 4204 mode: If any zone is programmed to "Report Only if Armed," skip to Prompt 55: "Enable Zn6."
45	Zn4 Trigger Type (V+)_	✓			<ul style="list-style-type: none"> • (EOLR) • (V+) • (V-) 	Selects the triggering method for this zone input. Press the [space] key to scroll through choices.
46	Invert Zn4 Y/N (N)_	✓			[Y], [N]	Inverts the alarm and normal states of the zone 4 trigger; otherwise uses normal input signal.
47	Restore Zn4 Y/N (Y)_	✓	✓		[Y], [N]	Enables restore reporting for zone 4.
48	Delay Zn4 (secs) (00)	✓	✓		[01-15] [00] = no delay	Defines the reporting delay in seconds for zone 4.
49	Rpt Zn4 ONLY if Armed (N)_	✓	2-4204 only		[Y], [N]	Reports alarms on zone 4 ONLY if the conditional zone (zone 7 in zone trigger mode; zone 8 in 2-4204 mode) is triggered (armed). If [N], always reports alarms on zone 4.
50	Zn5 Trigger Type (V+)_	✓			<ul style="list-style-type: none"> • (EOLR) • (V+) • (V-) 	Selects the triggering method for this zone input. Press the [space] key to scroll through choices.
51	Invert Zn5 Y/N (N)_	✓			[Y], [N]	Inverts the alarm and normal states of the zone 5 trigger; otherwise uses normal input signal.
52	Restore Zn5 Y/N (Y)_	✓	2-4204 only		[Y], [N]	Enables restore reporting for zone 5.
53	Delay Zn5 (secs) (00)_	✓	2-4204 only		[01-15] [00] = no delay	Defines the reporting delay in seconds for zone 5.

	PROMPTS	ZONE TRIG.	4204/2-4204	ENTRY	OPTIONS	DESCRIPTION
54	Rpt Zn5 ONLY if Armed (N)_	✓	2-4204 only		[Y], [N]	Reports alarms on zone 5 ONLY if the conditional zone (zone 7 in zone trigger mode; zone 8 in 2-4204 mode) is triggered (armed). If [N], always reports alarms on zone 5.
55	Enable Zn6 Y/N (N)_		4204 only		[Y], [N]	Enables alarm reporting for zone 6. If [N], skip to Prompt 61: "Enable Zn7."
56	Zn6 Trigger Type (V+)_	✓	4204 only		<ul style="list-style-type: none"> • (EOLR) • (V+) • (V-) 	Selects the triggering method for this zone input. Press the [space] key to scroll through choices.
57	Invert Zn6 Y/N (N)_	✓	4204 only		[Y], [N]	Inverts the alarm and normal states of the zone 6 trigger; otherwise uses normal input signal.
58	Restore Zn6 Y/N (Y)_	✓	✓		[Y], [N]	Enables restore reporting for zone 6.
59	Delay Zn6 (secs) (00)_	✓	✓		[01-15] [00] = no delay	Defines the reporting delay in seconds for zone 6.
60	Rpt Zn6 ONLY if Armed (N)_	✓	✓		[Y], [N]	Reports alarms on zone 6 ONLY if the conditional zone (zone 7 in zone trigger mode; zone 4 in 4204 mode; zone 8 in 2-4204 mode) is triggered (armed). If [N], always reports alarms on zone 6.
61	Enable Zn7 Y/N (N)_		4204 only		[Y], [N]	Enables alarm reporting for zone 7. If [N], skip to Prompt 69: "Use DHCP."
62	Zn7 Trigger Type (V+)_	✓	4204 only		<ul style="list-style-type: none"> • (EOLR) • (V+) • (V-) 	Selects the triggering method for this zone input. Press the [space] key to scroll through choices.
63	Invert Zn7 Y/N (N)_	✓	4204 only		[Y], [N]	Inverts the alarm and normal states of the zone 7 trigger; otherwise uses normal input signal.
64	Restore Zn7 Y/N (Y)_	✓	✓		[Y], [N]	Enables restore reporting for zone 7. Zone Trigger mode: This question will only be displayed if zone 7 is not used as the conditional (arming) trigger zone.
65	Delay Zn7 (secs) (00)_	✓	✓		[01-15] [00] = no delay	Defines the reporting delay in seconds for zone 7. Zone Trigger mode: This question will only be displayed if zone 7 is not used as the conditional (arming) trigger zone.
66	Rpt Zn7 ONLY if Armed (N)_		✓		[Y], [N]	Reports alarms on zone 7 ONLY if the conditional zone (zone 4 in 4204 mode; zone 8 in 2-4204 mode) is triggered (armed). If [N], always reports alarms on zone 7. 2-4204 mode: If any zone is programmed to "Report Only if Armed," or if tamper is enabled, skip to Prompt 69: "Use DHCP."
67	Restore Zn8 Y/N (Y)_		2-4204 only		[Y], [N]	Enables restore reporting for zone 8.
68	Delay Zn8 (secs) (00)_		2-4204 only		[01-15] [00] = no delay	Defines the reporting delay in seconds for zone 8.
69	Use DHCP Y/N (Y)_	✓	✓		[Y], [N]	Dynamically allocates the IP addresses (recommended); then skip to Prompt 74: "Enable Pwr Save". If [N], uses fixed IP addresses.

	PROMPTS	ZONE TRIG.	4204/2-4204	ENTRY	OPTIONS	DESCRIPTION
70	NIC IP Address: 255.255.255.255_	✓	✓		12 digit: xxx.xxx.xxx.xxx	Enter the 4-part address for this device. The 4 parts of the address must be separated by spaces (displayed as periods in Review mode).
71	Subnet Mask: 255.255.255.255_	✓	✓		12 digit: xxx.xxx.xxx.xxx	Enter the 32-bit address mask used to indicate the portion (bits) of the IP address that is being used for the subnet address. The 4 parts of the address must be separated by spaces (displayed as periods in Review mode).
72	Gateway IP Addr: 255.255.255.255_	✓	✓		12 digit: xxx.xxx.xxx.xxx [0.0.0.0.] = not used	Enter the 4-part address assigned to the Gateway. The 4 parts of the address must be separated by spaces (displayed as periods in Review mode).
73	DNS Serv IP Addr: 255.255.255.255_	✓	✓		12 digit: xxx.xxx.xxx.xxx [0.0.0.0.] = not used	Enter the 4-part IP address assigned to the DNS (Domain Name System) server. The 4 parts of the address must be separated by spaces (displayed as periods in Review mode).
74	Enable Pwr Save (Y)_	✓	✓		[Y], [N]	For 24 hour UL Battery Backup requirement, this feature must be enabled, or the unit must be powered by an appropriate UL listed UPS. If connectivity problems occur with certain routers or switches disable this option.
75	Review? Y/N	✓	✓		[Y] = review [N] = exit	Reviewing Programming Mode Entries To review the programming options (to ensure that the correct entries have been made), press [Y]. The programming questions are displayed again. Use the up/down arrow keys to scroll through the program fields without changing any of the values. If a value requires change, simply type in the correct value. When the last field is displayed, the "REVIEW?" question again appears. To exit the programming mode , press [N] in response to the "REVIEW?" question, and refer to <i>Exiting Programming Mode</i> below.

Exiting Programming Mode

To exit the programming mode, press [N] in response to the "REVIEW?" question. Then press [Y] to the "Exit Prog Mode?" question. Upon exiting, the root file is updated to log the changes made. A message is displayed telling the user that this step is being executed. When complete, the message "DONE" is displayed to indicate the file was successfully uploaded.



If critical configuration changes were made, such as the mode of operation, the 7845i-GSM will reset to ensure that the programming features are enabled.

If the file is not successfully uploaded, one of the following prompts will be displayed. Follow the steps shown below until the upload is successful.

Display	Description	What to do
Cannot Upload Try Again? Y/N_	7845i-GSM module is not yet initialized.	Wait for RSSI LEDs to be lit. Press [Y].
Failed to Update Root File!	Network problem, or you answered "N" to "Cannot Upload Try Again?" prompt.	Initiate the Force Server Update Command by pressing the [0] key; refer to <i>Section 5: Programmer Keyboard Commands</i> .

Setting Factory Defaults

To reset the programming options to factory-default values, press [ESC] at the "Exit Prog Mode?" prompt.

Set Default? Y/N_

Press [Y] to reset factory default values.

Press [N] to cancel this function.

If you press [Y], all programmed values are reset to the original factory settings. PLEASE NOTE THAT THIS WILL ERASE ANY PASSWORD THAT MAY HAVE BEEN ENTERED. After pressing [Y], the Create Password prompt appears (see Prompt 4).

Registration

In This Section

- ◆ Registering the 7845i-GSM

Registering the 7845i-GSM

Once you have initialized and programmed the 7845i-GSM, it must be registered to enable the account. An unregistered 7845i-GSM is indicated on the Status Display as: Status lit, Message slow blinking, and Fault not lit.

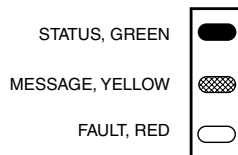

Figure 11. Unregistered 7845i-GSM Status Display In Normal Operation

Throughout this document, the following key is used to describe LED state:

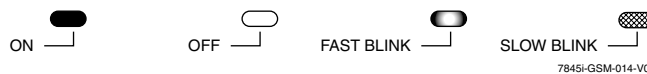

Figure 12. LED Key

Upon completion of the registration process, a 7845i-GSM transmits a registration message and receives a registration validation indicating that the account is now enabled. Wait for the "Registration Success" message to appear, regardless of which registration method used.

You can register the 7845i-GSM by one of the following methods:

- Through the AlarmNet Direct website
- Through use of the Tamper Switch
- Through use of a 7720P Programming Tool
- By phone

Register through AlarmNet Direct Website

If you have programmed the module through AlarmNet Direct, you must then transfer the data to the module, and register the module.

To do this, please go to: <https://services.alarmnet.com/AlarmNetDirect/userlogin.aspx>.

Log in and follow the on-screen prompts.

If you are not signed up for this service, click on "Dealer Signup" from the login screen to gain access to the Honeywell web-based programming.

Dealer Sign-Up Direct Link: https://services.alarmnet.com/AlarmNetDirectP_Sign-Up.

You will be instructed how to proceed upon completing the sign-up form. Only one sign-up per dealer is required. Once an initial user is established, additional logins may be created by that user.

Please have the following information available when programming the device:

1. Primary City ID (two-digit number)
2. Primary Central Station ID (two-digit hexadecimal number)
3. Primary Subscriber ID (four-digit number)
4. MAC ID and MAC CRC number (located on outside of box and on label inside module) or MIN number of the device you are replacing.
5. Mode of operation of existing module if replacing a "C" series radio.

Once module is registered, you may log out of the AlarmNet Direct website.

Register using the Tamper Switch

Initiate the registration sequence by clicking the Tamper Switch three times.

You can monitor the registration process by viewing the Status Display. The Message (yellow) LED and the Status (green) LED will blink slowly in unison while registration is in progress.

Once the registration has been completed successfully, the 7845i-GSM enters normal operating mode; the Status (green) LED goes out and the Message (yellow) LED is lit to indicate that the power-on / reset message is waiting to be sent. This message will appear at the receiving station as "E339 8xx", where "xx" is the ECP device address. The description may read "Trouble – Exp. Mod. Reset". If registration is not validated within 90 seconds, the 7845i-GSM times out, and the (green) LED will be lit (solid).

The power-on/reset message will be sent in ADEMCO High-Speed format if the module is programmed for zone trigger, 4204 or 2x4204 modes.

If repeated registration attempts time out, check your Internet connection and RSSI level, and verify that 7845i-GSM account information has been entered correctly.

Register using the Programming Tool

The interactive registration feature allows the installer to register the 7845i-GSM through a series of keyboard commands on the 7720P Programming Tool. This method of registration lets the installer monitor the registration process.

Registering ...

Once the installation is complete, press the [↑] key on the 7720P. The registration message is sent and the unit waits for the acknowledgment.

Registration
SUCCESS

If this is a new installation and the city, central station, and customer numbers have been correctly entered, the 7845i-GSM is registered and this message is displayed. The 7845i-GSM is now in full service and available for alarm reporting to the central station.

Possible Errors

Registration BAD
Timed Out

Displayed if no response to the registration request is received.

Registration BAD Pri Sub ID BAD	Indicates the city, central station, or customer number for the labeled account(s) is not accepted. The ID information was either entered in error, or the central station failed to pre-authorize programmed ID numbers with AlarmNet customer service.
Registration BAD 2 nd Sub ID BAD	Indicates the city, central station, or customer number for the Secondary account is not accepted. The ID information was either entered in error, or the central station failed to pre-authorize programmed ID numbers with AlarmNet customer service.
Registration BAD Pri&Sec – IDs BAD	Displayed when both primary and secondary subscriber IDs are invalid.
Registration BAD Pri ID – Need PIN	Displayed if this is a repair/replacement, or an error was made in programming the Primary account information of 7845i-GSM for an existing account. This prompt appears for 2 seconds. See the <i>Replacing an existing module</i> section below for further displays.
Registration BAD 2 nd ID – Need PIN	This prompt is displayed if this is a repair/replacement, or an error was made in programming the Secondary account information of 7845i-GSM for an existing account. This prompt appears for 2 seconds. See the <i>Replacing an existing module</i> section below for further displays.
Registration BAD Pri&2 nd – Need PIN	This prompt is displayed if this is a repair/replacement, or an error was made in programming BOTH the Primary and Secondary account information of 7845i-GSM for an existing account. This prompt appears for 2 seconds. See the <i>Replacing an existing module</i> section below for further displays.

Replacing an existing module using the programming tool

Enter PIN#	<p>This prompt appears after pressing the down arrow [↓] on the 7720P.</p> <p>Note: If it is necessary to exit registration mode, press ESC from the 7720P programming tool.</p> <p>Enter a 4-digit alphanumeric PIN number provided by your central station, your dealer or an authorized AlarmNet representative.</p> <p>NOTE: If you are replacing an existing "C Series" module, you can enter the last four-digits of the "C Series" MIN number.</p> <p>Press the [ENTER] key.</p>
Registering ...	The registration message is sent and the unit waits for acknowledgement.
Registration SUCCESS	If the PIN is valid, the new 7845i-GSM is registered and the old unit unregistered. Additionally, AlarmNet sends a substitution alarm to the central station.

Registration BAD

If you entered an invalid PIN, the appropriate message is displayed depending on which account number is being replaced (see above for exact wording). The registration process is repeated.

NOTE: Each attempt causes a substitution alarm to be sent to the central station.

Register by Phone

You can register the module by calling the AlarmNet Technical Assistance Center (TAC) at 1-800-222-6525.

You will need the following information:

- MAC number (found on the label).
- Subscriber information (provided by the central station), including a city code, CSID, and a subscriber ID.
- When instructed to do so, triple-click the tamper switch to complete the registration.

Programmer Keyboard Commands

Programmer Keyboard Commands

Programmer keyboard commands can be used to quickly view your connectivity settings and options. Most commands require you to press the [shift] key and then the designated command key. (See the keys designated in red on the 7720P Programming Tool.)

[A]

7845iGSM x.x.xx mm/dd/yy
--

Software Revision
"x.x.xx" indicates the installed software Revision.
Mm/dd/yy indicates month, day and year of the revision.

Module Identification Displays

[B]

MAC xxxxxxxxxxxx MAC CRC yyyy
--

MAC Address
"xxxxxxxxxxxx" indicates the 7845i-GSM's unique identification number.
"yyyy" indicates the MAC CRC number. This number is also found on the label on the module, as well as the label on the box.

Press the [space] key to go to the next field.
Press the [backspace] key to go to the previous field.

SCID xxxxx xxxxx xxxxx xxxxx
--

SCID Display
Displays the identification number assigned to the SIM card (SCID) in this device.
Press the [space] key to go to the next field.
Press the [backspace] key to go to the previous field.

IMEI xxxxxxxx xxxxxx x

IMEI Display
Displays the identification number assigned to the 7845i-GSM module in this device.
Press the [space] key to get the MAC Address.
Press the [backspace] key to go to the previous field.

[C]

Mon 01 Jan 2001 05:48:39 am

Time
Retrieves the current date and time from the AlarmNet network in Greenwich Mean Time (GMT). This display confirms that the module is in sync with network.

[D]

Physical Link Good/Bad

Network Diagnostics Display
Indicates whether the device has detected a physical connection to the internet.
Press the [space] key to go to the next field.

NIC IP Address xxx.xxx.xxx.xxx

IP Information Display
Displays the IP address assigned to this device.
Press the [space] key to go to the next field.

Subnet Mask xxx.xxx.xxx.xxx

 Displays the 32-bit address mask used to indicate the portion (bits) of the IP address that is being used for the subnet address.

Press the [space] key to go to the next field.
Press the [backspace] key to go to the previous field.

Gateway IP Addr xxx.xxx.xxx.xxx

 Displays the IP address assigned to the Gateway.
Press the [space] key to go to the next field.
Press the [backspace] key to go to the previous field.

DNS Serv IP
xxx.xxx.xxx.xxx

Displays the IP address assigned to the DNS (Domain Name System) server.
Press the [space] key to go to the next field.

Encryption Test
AES Passed!

Press the [backspace] key to go to the previous field.
Performs a self-test of the AES encryption algorithm.
Press the [space] key to go to the next field.

DHCP
OK

Press the [backspace] key to go to the previous field.
DHCP (Dynamic Host Configuration Protocol) indicates server is performing satisfactorily.
Press the [space] key to go to the Physical Link display.

GSM Status Displays

[E]

PriRSSI GPRS REG
-xxxdbm x x

GSM Status Display Screen 1

PriRSSI – Primary Site RSSI level in dbm
GPRS – GPRS Service availability where “x” can be:
“Y” if GPRS is available
“N” if GPRS is Not available
REG – Registration status from radio module where “x” can be:
N – Not Registered
H – Registered Home
S – Searching
D – Registration Denied
R – Registered Roaming
? – Unknown Registration State

Press the [space] key to go to the next screen.
Press the [backspace] key to go to the last screen.

Cntry Netw LAC
xxx xxx xxxxx

GSM Status Display Screen 2

Cntry – Country Code
Netw – Network Code
LAC – Local area code
Press the [space] key to get to the next screen.
Press the [backspace] key to go to the previous field.

Cell BaseSt Chan
xxxxx x xxx

GSM Status Display Screen 3

Cell – Base Station ID
BaseSt – Base Station Antenna Sector
Chan – Control Channel in use
Press the [space] key to go to the next screen.
Press the [backspace] key to go to the previous field.

Second Site RSSI
-xxxdbm

GSM Status Display Screen 4

Secondary GSM Site RSSI level in dBm.
Press the [space] key to go to the GSM Status Display Screen 1.
Press the [backspace] key to go to the previous field.

[F]

Testing Gateway
Redir 1

Run Network Diagnostic Test

Performs a set of network diagnostics that tests the integrity of the links between the 7845i-GSM and the various connection points (Redirs) to AlarmNet. Refer to Section 6: *Network Diagnostics*.

System Status Displays

[S]

ECP 67 TmPB Flt
xx 5 ++ OK

ECP Mode

Displays the zone and system fault status.
Press the [space] key to go to the next field.
Press the [backspace] key to go to the previous field.

```
1234 67 TmPB Flt
5555 xx 5 ++ OK
```

```
12345678 TmPB Flt
5555555x 5 ++ OK
```

```
1234567 TmPB Flt
5555555 5 ++ OK
```

4204 Emulation Mode

Displays the zone and system fault status.
Press the [space] key to go to the next field.
Press the [backspace] key to go to the previous field.

Two-4204 Emulation Mode

Displays the zone and system fault status.
Press the [space] key to go to the next field.
Press the [backspace] key to go to the previous field.

Zone Trigger Mode

The status of the 7845i-GSM can be viewed on the 7720P. The status display includes:

- **Zone input status (1234567)** - the numbers 1-7 represent the 7 mappings of the zone input, and follow Honeywell's ADEMCO high-speed format codes:
 - 1** = New Event
 - 5** = Normal
 - X** = Not Enabled
- **Tm** – Tamper status follows high-speed format codes above.
- **P** – Represents line voltage as follows:
 - +** = Power line voltage OK
 - = Power line voltage bad and reported
 - V** = Power line voltage bad, not reported (reporting window not expired)
 - ^** = Power voltage restored, not yet reported
- **B** – Represents battery condition as follows:
 - +** = Battery voltage acceptable
 - = Battery voltage below 5.7V ±5%
- **Flt** – Represents radio faults:
 - OK** = Normal ; No fault
 - I** – No network connectivity over IP and fault time has expired
 - i** – No network connectivity over IP and fault time has NOT yet expired.
 - G** = No network connectivity over GSM and fault time has expired.
 - g** = No network connectivity over GSM and fault time has NOT yet expired.

NOTE: The 7720P will not operate if the power line voltage is removed.

```
Bat NLd: x.xxV
Bat Ld:  x.xxV
```

Battery Voltage Display

The voltage levels of the battery connected to the 7845i-GSM can be viewed on the 7720P. The first line of the display shows the voltage level of the battery with no load. The second line of the display shows loaded battery voltage. An asterisk (*) next to the voltage indicates that this is below the accepted level.
Press the [space] key to go to the next field.
Press the [backspace] key to go to the previous field.

	Battery Charger OK	<p>Battery Charger Status Display The status of the battery charger circuit of the 7845i-GSM can be viewed on the 7720P. The status is either OK or NOT OK. Press the [space] key to go to the next field. Press the [backspace] key to go to the previous field.</p>
	Line Voltage xx.xxV	<p>Line Voltage Display The line voltage of the 7845i-GSM can be viewed on the 7720P. An asterisk (*) next to the voltage indicates that this is below the accepted level. Press the [space] key to go back to the System Status Display. Press the [backspace] key to go to the previous field.</p>
[T]	Test Msg Sent	<p>Test Alarm Sends a Test alarm to AlarmNet. Functional for a <i>registered</i> 7845i-GSM only. If the device is not registered, a message is displayed indicating that the command cannot be executed.</p>
[X]	Reset CPU Y/N	<p>Reset the 7845i-GSM. Pressing [N] returns to diagnostic mode (blank screen = enter next command or escape). Pressing [Y] resets the module (blank screen = reset complete).</p>
[↑] (UP arrow)	Registering ...	<p>Registration Registers a programmed 7845i-GSM with AlarmNet.</p>
[↓] (DN arrow)	Enter PIN#	<p>Registration with PIN for Replacement Module Registers a replacement 7845i-GSM with AlarmNet, once programmed, using the existing PIN #.</p>
[0]	Force Server Update? Y/N	<p>Force Upload of Configuration File to Server Pressing [Y] will force the device to upload its entire configuration file to the server. Pressing [N] cancels the operation. NOTE: If the internet is not available, and the 7845i-GSM module is not initialized when you enter this command, the following screen will be displayed:</p>
	Cannot Upload Try Later! _	<p>Wait for the RSSI LEDs to light, indicating the 7845i-GSM module has completed its initialization, and try again.</p>
[ENTER]	Strt Prog Mode? Y/N_	<p>Enter Program Mode Press [Y] to enter program mode; otherwise, press [N].</p>

Network Diagnostics

In This Section

◆ *Running Network Diagnostics on the 7845i-GSM*

Running Network Diagnostics on the 7845i-GSM

The network diagnostic process tests the integrity of the links between the 7845i-GSM and the various connection points of AlarmNet Control that are known as "Redirs".

To initiate the network diagnostics, press the [F] key on the 7720P Programming Tool.

NOTE: The test is performed ONLY if a physical link is detected. If no physical link is detected, the test is aborted and the following is displayed:

NO PHYSICAL LINK

If a physical link is detected, the diagnostics are performed. The following shows the progression of the test:

Testing Redir 1

The first step of the test traces the connection to Redir 1 at AlarmNet Control.

Testing Redir 2
Reached Gateway

A successful trace to Redir 1 is indicated here. See below for possible errors that may occur at this stage of testing.

Redir 1
Service OK

The service at AlarmNet Control on Redir 1 is functioning. See below for possible errors that may occur at this stage of testing.

Testing Redir 2

The first step of the test traces the connection to Redir 2 at AlarmNet Control.

Redir 2
Service OK

The service at AlarmNet Control on Redir 2 is functioning. See below for possible errors that may occur at this stage of testing.

Testing Redir 3

The first step of the test traces the connection to Redir 3 at AlarmNet Control.

Redir 3
Service OK

The service at AlarmNet Control on Redir 3 is functioning. See below for possible errors that may occur at this stage of testing.

RDR1 RDR2 RDR3
OK OK OK

A summary of the tests is displayed after Redir 3 is tested. The example shows that the tests of all three connection points, or Redirs, were successful. If an error occurred at any point, the summary will display "FAIL" under the faulty Redir.

Appendix A: Summary of LED Operation

7845i-GSM Status Display Operation

The 7845i-GSM Status Display has three LEDs used to indicate message and device status:

- STATUS, *green*
- MESSAGE, *yellow*
- FAULT, *red*

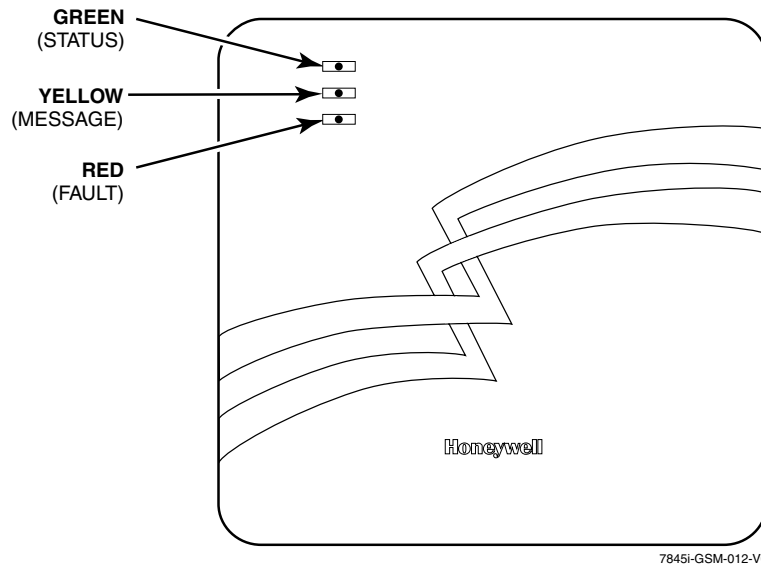

Figure 13. 7845i-GSM Status Display LEDs with Front Cover Installed

Each LED can have four different states - ON, OFF, FAST BLINK and SLOW BLINK. Throughout this document, the following key is used to describe LED state:

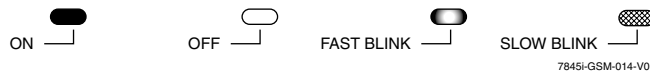

Figure 14. LED Key

Table 6. Status Display Operation

LED COLOR	LED	DESCRIPTION
GREEN	STATUS	ON – 7845i-GSM is NOT registered with AlarmNet. OFF – 7845i-GSM is registered with AlarmNet. FAST BLINK – Download session with Compass in progress. SLOW BLINK – In unison with yellow LED – Registration in progress.
YELLOW	MESSAGE	ON – Message transmission pending. QUICK PERIODIC BLINK – Normal. FAST BLINK – Message waiting for network ACK. SLOW BLINK – Idle, power abnormal. – In unison with green LED – Registration in progress.
RED	FAULT	ON – No contact with network. OFF – Normal. SLOW BLINK – Loss of communication with the panel (ECP fault). FAST BLINK – No network contact AND loss of communication with the panel.
ALL		FAST BLINK – In unison with the RSSI Bar Graph LEDs – Hardware Error. Call the AlarmNet Technical Assistance Center.

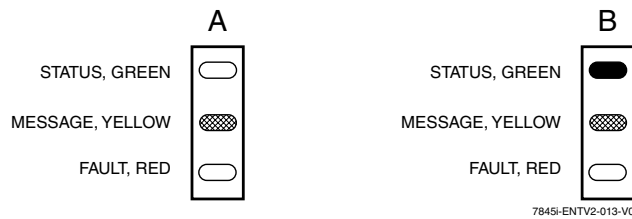

Figure 15. A Registered 7845i-GSM Status Display (A) and an Unregistered 7845i-GSM Status Display in Normal Operating State (B)

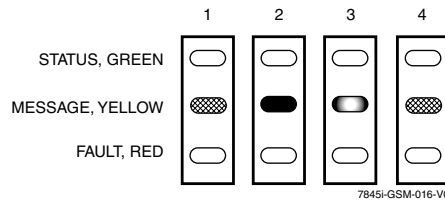

Figure 16. LED Sequence for a Registered 7845i-GSM Message Transmission

Network Connectivity Display

The Network Connectivity LED display can only be viewed with the cover removed. It is used as a visual indication of 7845i-GSM network activity. Every 15-20 seconds the LEDs turn on to indicate status.

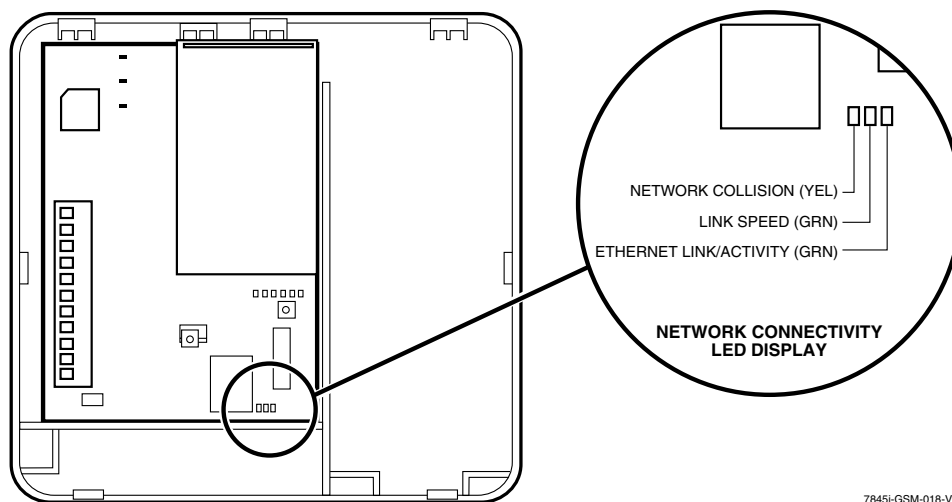

Figure 17. 7845i-GSM Network Connectivity Display

The Network Connectivity Display consists of three LEDs. They function as follows:

Table 7. Network Connectivity Display

LED COLOR	LED LABEL	DESCRIPTION
YELLOW	NETWORK COLLISION	BLINKING – Network collision detected. OFF – Normal.
1 ST GREEN	LINK SPEED	ON – 100 MB/S link to Internet. OFF – 10 MB/S link to Internet.
2 ND GREEN	ETHERNET LINK / ACTIVITY	ON – Ethernet link detected. OFF – No Ethernet link detected. FAST BLINK – Transmitting/Receiving Data.

Signal Strength (RSSI) / Mode and Status LEDs

The Signal Strength (RSSI) / Mode and Status LEDs normally display the module’s signal strength. LED 1 (red LED on the left) will be lit to indicate that the display is in RSSI mode, and the other LEDs indicate signal strength (lowest to highest, from left to right) between the module and the receiving tower. Signal strength should be within 3-5 bars.

Mode and Status Indicator Switch

Press and hold the Mode and Status Indicator Switch to change the LED functions in order to view the mode of operation and network carrier status. When the switch is held down, LED 1 (red LED on the left) will be off, and the LEDs from left to right have the following meanings:

Table 8. LED Functions with Mode and Status Indicator Switch Depressed

Operation Modes (Table 8a)			Status Indications (Table 8b)		
LED 1 (red)	LED 2 (yellow)	LED 3 (yellow)	LED 4 (green)	LED 5 (green)	LED 6 (green)
Off=Mode and Status indicator	Operation Mode (in combination with LED 3)	Operation Mode (in combination with LED 2)	Web Connection	GPRS Service	7845i-GSM Module Registration with Network Carrier

(See below for specific modes and status indications)

Table 8a. Operation Modes

OPERATION MODE	LED 2 (1 st yellow)	LED 3 (2 nd yellow)
ECP	OFF	OFF
Zone	ON	OFF
4204	OFF	ON
2 - 4204	ON	ON

Table 8b. Status Indications

STATUS	LED 4 (1 st green)	LED 5 (2 nd green)	LED 6 (3 rd green)
OFF	No Web Connection	No GPRS service available	7845i-GSM module not registered with network carrier
SLOW BLINK	–	–	7845i-GSM module registered—second site available—low signal strength
NORMAL BLINK	–	–	7845i-GSM module registered—second site available—acceptable signal strength
FAST BLINK	–	GPRS in use by device	7845i-GSM module registered—second site available—excellent signal strength
ON	Connected to Web	GPRS service available	7845i-GSM module registered—no second site available

Appendix B: Central Station Messages

The following messages are sent by the 7845i-GSM module for the conditions listed below.

Table 9: 7845i-GSM Central Station Messages

Alarm Condition	ECP Mode Alarm Code	ECP Mode Restore Code	Zone and 4204 Modes Alarm Code	Zone and 4204 Modes Restore Code
Power On Reset	E339 C08xx*		5551 5555 6	
Tamper	E341 C08xx*	R341C 08xx*	5555 5551 7	5555 5553 7
Power Loss	E337 C08xx*	R337 C08xx*	1555 5555 6	3555 5555 6
Low Battery	E338 C08xx*	R338 C08xx*	5155 5555 6	5355 5555 6
Battery Charger Failure	E314 C08xx*	R314 C08xx*	5155 5555 1	5355 5555 1
ECP Supervision	E355 C0000	R355 C0000	5555 5515 5	5555 5535 5
Primary Communication Path Supervision	E350 C0951	R350 C0951	5555 5551 5	5555 5553 5
Secondary Communication Path Supervision	E350 C0952	R350 C0952	5555 5551 1	5555 5553 1
Swinger Suppression			0D00 0005 0	
Telco			5555 5155 6	5555 5355 6
Open/Close			2 sent in selected zone	4 sent in selected zone
Test	5555 5555 9		5555 5555 9	

* xx = 7845i-GSM Device Address

The control panel sends its own general code (E353) for a trouble condition.

Appendix C: IP Downloading

General Information

The 7845i-GSM can be used to provide high-speed up/downloading to Honeywell VISTA and LYNXR-I control panels. This allows site maintenance independent of central station monitoring, and modification to sites globally via the internet. At this time, some control panels support Direct Wire downloading and some panels support downloading through the ECP bus. Residential panels that support IP downloading (e.g., VISTA-20P, LynxR-I) are connected to the 7845i-GSM through the ECP bus. Currently, commercial controls such as VISTA-128BP and FBP support IP downloading through use of a Direct Wire connection (using the trigger cable).

UL Downloading may only be performed if a technician is at the site.

Direct Wire Setup

To perform IP up/downloading using Direct Wire, the 7845i-GSM requires that Direct Wire Downloading over IP programming is enabled (Direct Wire Y/N), and that the ECP device address on which the 7845i-GSM communicates with the control panel as a keypad is entered (Keypad Address). Additionally, the 7845i-GSM must be connected by cable as shown below to the panels listed.

NOTES:

1. For Direct Wire IP downloading on Commercial Fire panels (e.g. VISTA-128FBP, FA1700C), Program Field 3*19 **Enable J2 Header Printer Port** must be set to "1".
2. This feature is not available if device is set for zone trigger mode.

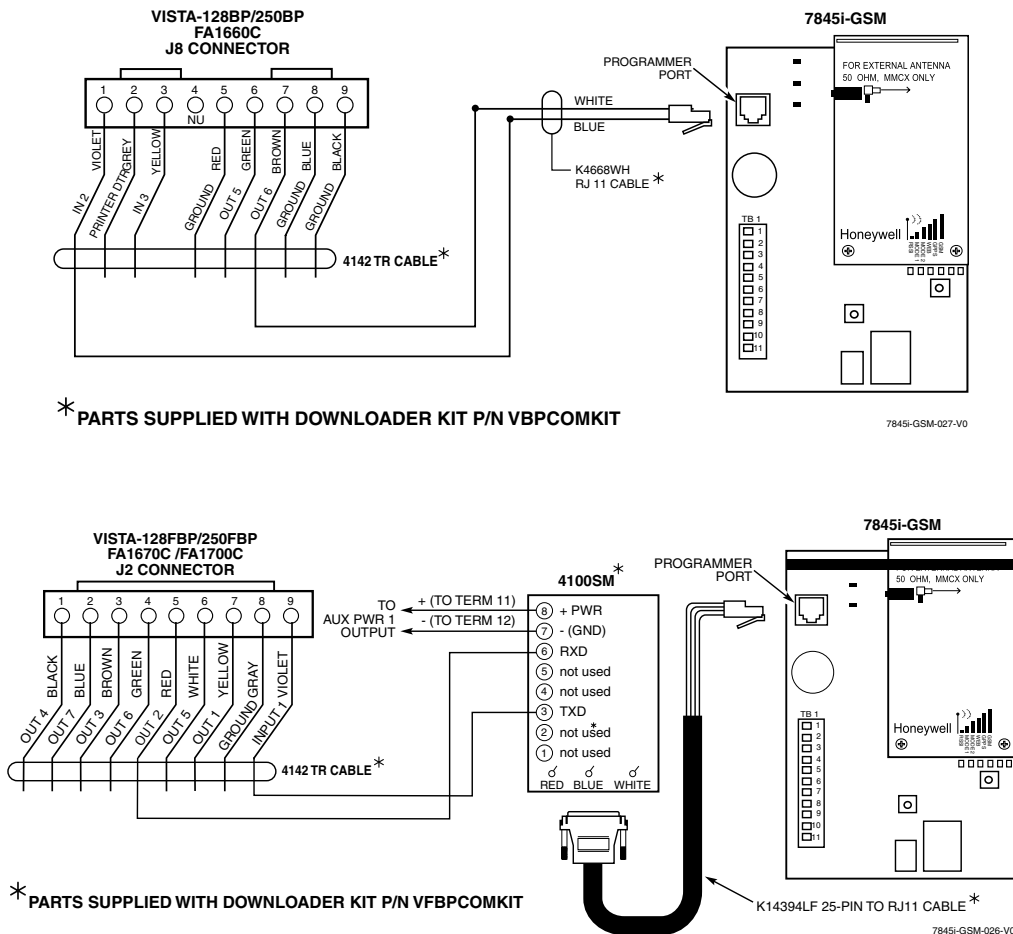

Figure 18. Cable Connections for IP Downloading

Appendix D: Glossary

AES – Advanced Encryption Standard

DHCP – Dynamic Host Configuration Protocol, which provides a mechanism for allocating IP addresses dynamically so that addresses can be reused when hosts no longer need them.

DNS – Domain Name System, which is a distributed hierarchical naming system used to resolve domain names (e.g., www.yahoo.com) into numerical IP addresses (e.g., 204.17.25.1).

DSL – Digital Subscriber Line

ECP – Enhanced Console Protocol, which is a proprietary communications bus used in Honeywell VISTA control panels for wiring additional keypads and peripheral devices; consists of a four-wire data bus (power +/-, data in/out).

Gateway IP Address – A gateway (sometimes called a router) is a computer and/or software used to connect two or more networks (including incompatible networks) and translates information from one network to the other. The Gateway IP address is the IP address for the gateway.

GPRS – (General Packet Radio Service)

GSM – Global System for Mobile communications, which is an international standard for digital mobile phone systems used for cellular communication.

IMEI – International Mobile Equipment Identity number

IP – Internet Protocol

IP Address – A unique number consisting of four parts separated by periods, sometimes called a "dotted quad.," for example: 204.17.29.11, assigned to every computer/workstation connected to the Internet. IP numbers can be "static" (assigned and unchanging) or "dynamic," assigned via DHCP at each and every startup.

ISDN – Integrated Services Digital Network

ISP – Internet Service Provider

LAN – Local Area Network

MAC ID – Media Access Code; located on the module label.

Subnet Mask – A Subnet is a portion of a network that shares a network address with other portions of the network, and is distinguished by a subnet number. The Subnet Mask is a 32-bit address mask used in IP to indicate the bits of an IP address that are being used for the subnet address.

TCP/IP – Transmission Control Protocol / Internet protocol

FCC AND INDUSTRY CANADA STATEMENT

This device complies with Part 15 of the FCC Rules and RSS210 of Industry Canada. Operation is subject to the following two conditions: (1) This device may not cause harmful interference, and (2) this device must accept any interference received, including interference that may cause undesired operation.

This Class B digital apparatus complies with Canadian ICES-003.

Cet Appareil numérique de la classe B est conforme à la norme NMB-003 du Canada.

FEDERAL COMMUNICATIONS COMMISSION (FCC) STATEMENT

This equipment has been tested to FCC requirements and has been found acceptable for use. The FCC requires the following statement for your information:

This equipment generates and uses radio frequency energy and if not installed and used properly, that is, in strict accordance with the manufacturer's instructions, may cause interference to radio and television reception. It has been type tested and found to comply with the limits for a Class B computing device in accordance with the specifications in Part 15 of FCC Rules, which are designed to provide reasonable protection against such interference in a residential installation. However, there is no guarantee that interference will not occur in a particular installation. If this equipment does cause interference to radio or television reception, which can be determined by turning the equipment off and on, the user is encouraged to try to correct the interference by one or more of the following measures:

- If using an indoor antenna, have a quality outdoor antenna installed.
- Reorient the receiving antenna until interference is reduced or eliminated.
- Move the radio or television receiver away from the receiver/control.
- Move the antenna leads away from any wire runs to the receiver/control.
- Plug the receiver/control into a different outlet so that it and the radio or television receiver are on different branch circuits.

If necessary, the user should consult the dealer or an experienced radio/television technician for additional suggestions. The user or installer may find the following booklet prepared by the Federal Communications Commission helpful:

"Interference Handbook"

This booklet is available under Stock No. 004-000-00450-7 from the U.S. Government Printing Office, Washington, DC 20402.

The user shall not make any changes or modifications to the equipment unless authorized by the Installation and Setup Guide or User Guide. Unauthorized changes or modifications could void the user's authority to operate the equipment.

7845i-GSM Summary of Connections

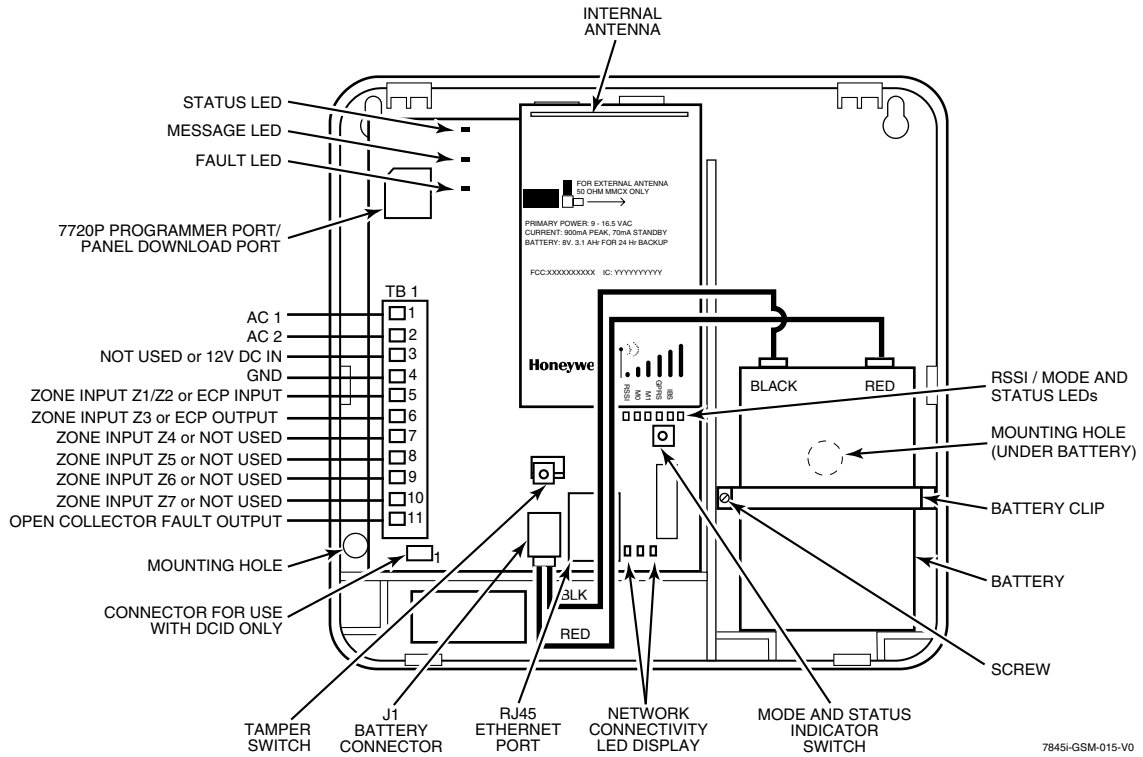

7845i-GSM-015-V0

TB1 Wiring for 7845i-GSM Cellular Communicator

TB1	ECP Mode	Zone Trigger Mode	4204 Mode	2 x 4204 Mode
1	AC 1	AC 1	AC 1	AC 1
2	AC 2	AC 2	AC 2	AC 2
3	ECP V+ (RED)	NOT USED	ECP V+ (RED)	ECP V (RED)+
4	GND (BLK)	GND (BLK)	GND (BLK)	GND (BLK)
5	ECP IN (YEL)	Z1/Z2	ECP IN (YEL)	ECP IN (YEL)
6	ECP OUT (GRN)	Z3	ECP OUT (GRN)	ECP OUT (GRN)
7	NOT USED	Z4	NOT USED	NOT USED
8	NOT USED	Z5	NOT USED	NOT USED
9	Z6	Z6	Z6	NOT USED
10	Z7	Z7	Z7	NOT USED
11	FLT OUT	FLT OUT	FLT OUT	FLT OUT

LIMITED WARRANTY

Honeywell International Inc., acting through its Security & Custom Electronics business ("Seller"), 2 Corporate Center Drive, Melville, NY, 11747, warrants its product(s) to be in conformance with its own plans and specifications and to be free from defects in materials and workmanship under normal use and service for 24 months from the date stamp control on the product(s) or, for product(s) not having a manufacturer's date stamp, for 12 months from date of original purchase unless the installation instructions or catalog sets forth a shorter period, in which case the shorter period shall apply. Seller's obligation shall be limited to repairing or replacing, at its option, free of charge for materials or labor, any product(s) which is proved not in compliance with Seller's specifications or proves defective in materials or workmanship under normal use and service. Seller shall have no obligation under this Limited Warranty or otherwise if the product(s) is altered or improperly repaired or serviced by anyone other than Honeywell factory service. Connection of any device(s) to a communicating bus of a Honeywell security system (e.g., keypad bus, polling loop) other than those manufactured or approved by Honeywell shall void this warranty. For warranty service, return product(s) transportation prepaid, to your local authorized Honeywell representative.

THERE ARE NO WARRANTIES, EXPRESS OR IMPLIED, OF MERCHANTABILITY, OR FITNESS FOR A PARTICULAR PURPOSE OR OTHERWISE, WHICH EXTEND BEYOND THE DESCRIPTION ON THE FACE HEREOF. IN NO CASE SHALL SELLER BE LIABLE TO ANYONE FOR ANY CONSEQUENTIAL OR INCIDENTAL DAMAGES FOR BREACH OF THIS OR ANY OTHER WARRANTY, EXPRESS OR IMPLIED, OR UPON ANY OTHER BASIS OF LIABILITY WHATSOEVER, EVEN IF THE LOSS OR DAMAGE IS CAUSED BY THE SELLER'S OWN NEGLIGENCE OR FAULT.

Seller does not represent that the product(s) it sells may not be compromised or circumvented; that the product(s) will prevent any personal injury or property loss by burglary, robbery, fire or otherwise; or that the product(s) will in all cases provide adequate warning or protection. Customer understands that a properly installed and maintained alarm system may only reduce the risk of a burglary, robbery, fire, or other events occurring without providing an alarm, but it is not insurance or a guarantee that such will not occur or that there will be no personal injury or property loss as a result. CONSEQUENTLY, SELLER SHALL HAVE NO LIABILITY FOR ANY PERSONAL INJURY, PROPERTY DAMAGE OR OTHER LOSS BASED ON A CLAIM THAT THE PRODUCT(S) FAILED TO GIVE WARNING. HOWEVER, IF SELLER IS HELD LIABLE, WHETHER DIRECTLY OR INDIRECTLY, FOR ANY LOSS OR DAMAGE ARISING UNDER THIS LIMITED WARRANTY OR OTHERWISE, REGARDLESS OF CAUSE OR ORIGIN, SELLER'S MAXIMUM LIABILITY SHALL NOT IN ANY CASE EXCEED THE PURCHASE PRICE OF THE PRODUCT(S), WHICH SHALL BE THE COMPLETE AND EXCLUSIVE REMEDY AGAINST SELLER.

This warranty replaces any previous warranties and is the only warranty made by Seller on this product(s). No increase or alteration, written or verbal, of the obligations of this Limited Warranty is authorized.

Honeywell

2 Corporate Center Drive, Suite 100
P.O. Box 9040, Melville, NY 11747
Copyright© 2007 Honeywell International Inc.

www.security.honeywell.com



K14168V2 8/07 Rev. A